

## Fitness Range

FS001N, FS004N, FS007N, FS009N,  
FS010N, FS015N, FS016N, FS030,  
FS031, FS032, FS033, FS034,  
FS035, FS036, FS037, FS038, FS100  
FS101, FS102, FS103, FS104, FS105  
FS106, FS107, FS108, FS112, FS113

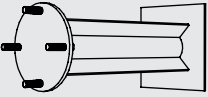
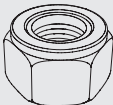
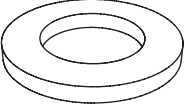
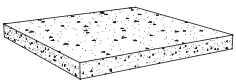

ITEM	REF	PART	Qty	ITEM	REF	PART	Qty
1	940301		1	2	10261600	 M16	4
3	10291600	 M16	4	4	<del>INCL INCL</del>	 500 x 500 x 50mm	1

## Fitness Range Ground Anchor

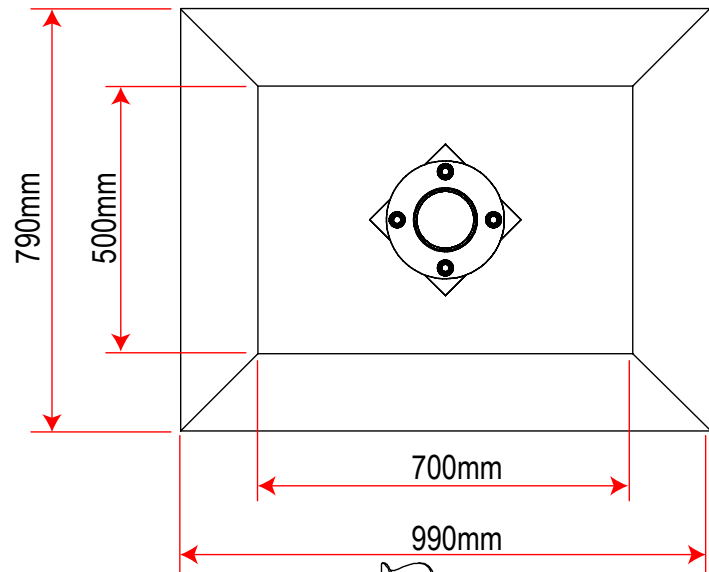



S2 (50mm)  
≥C20-25



7 x 24h



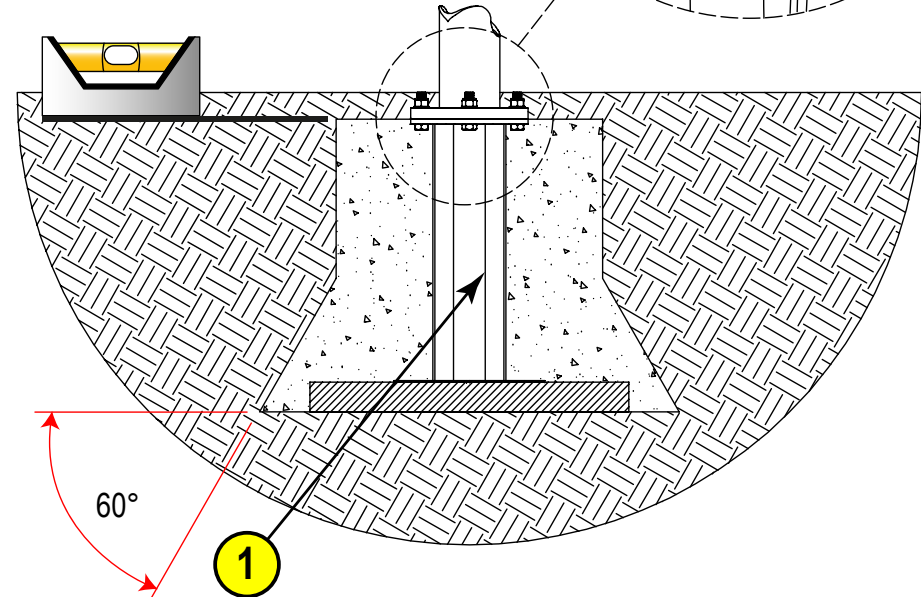
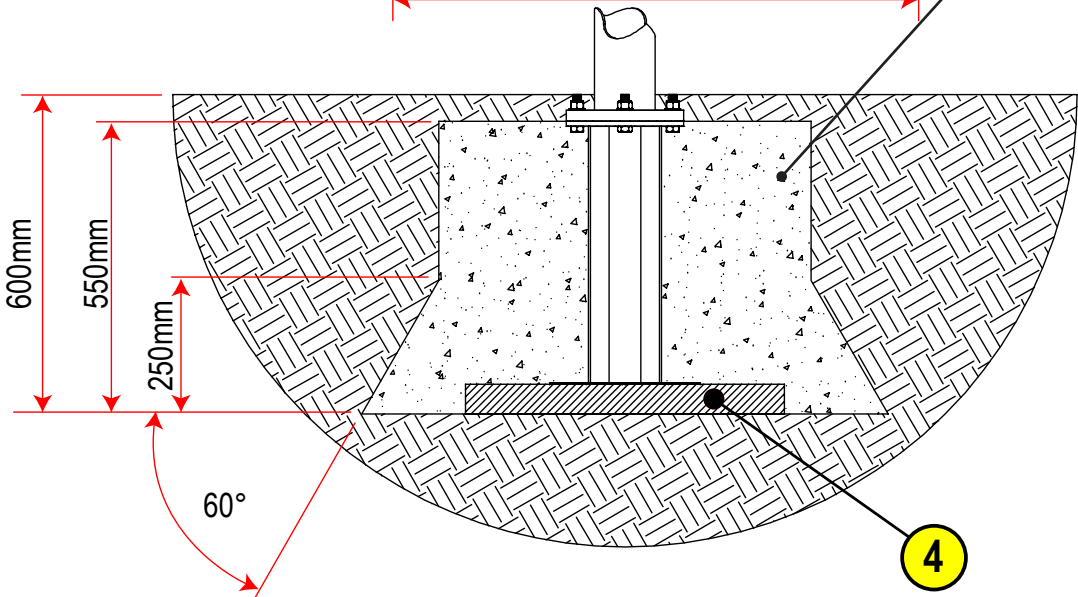
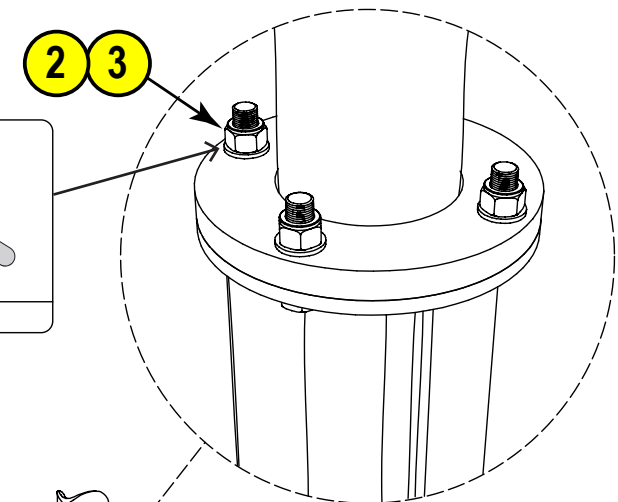
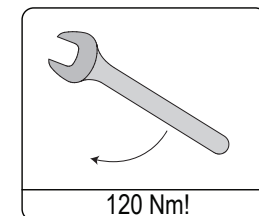

101

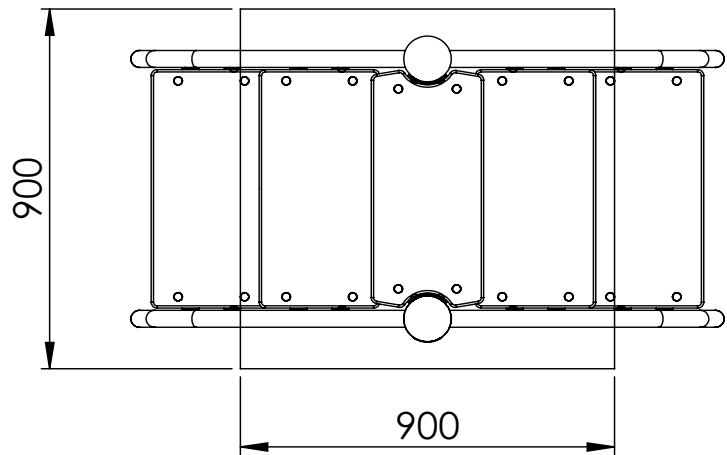
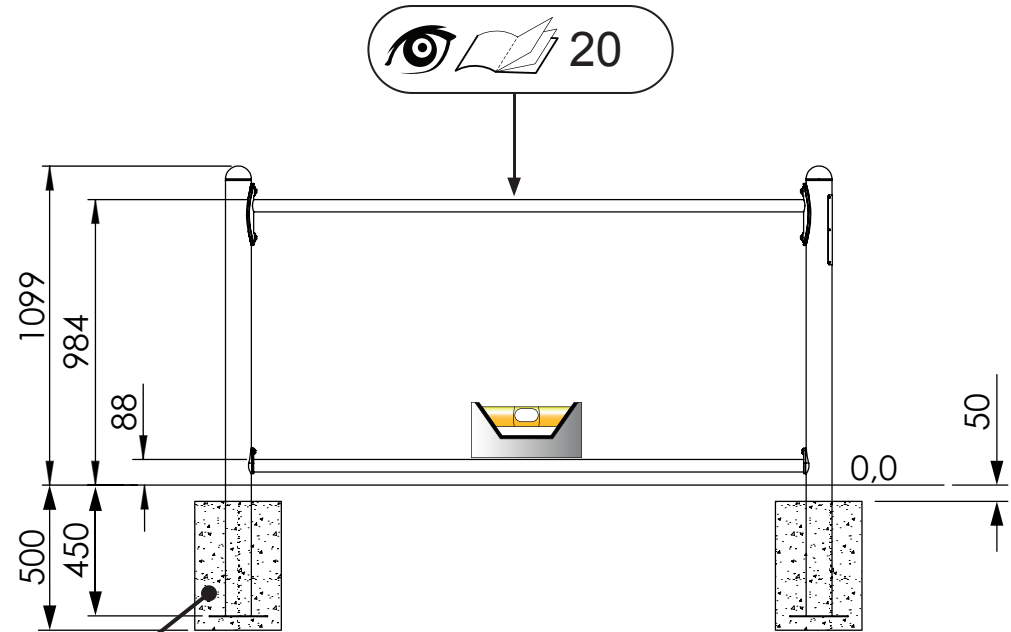
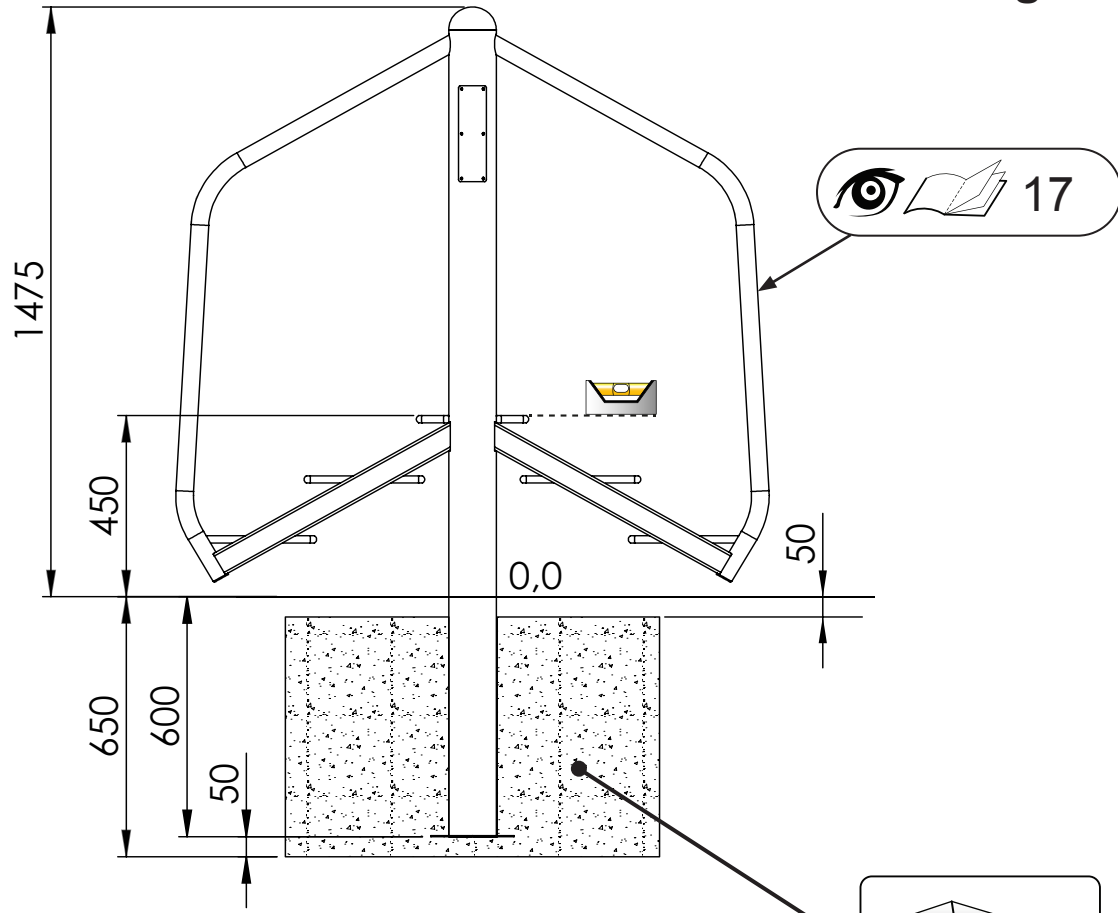

# Footing detail for FS035 Step Challenge & FS037 Ladder





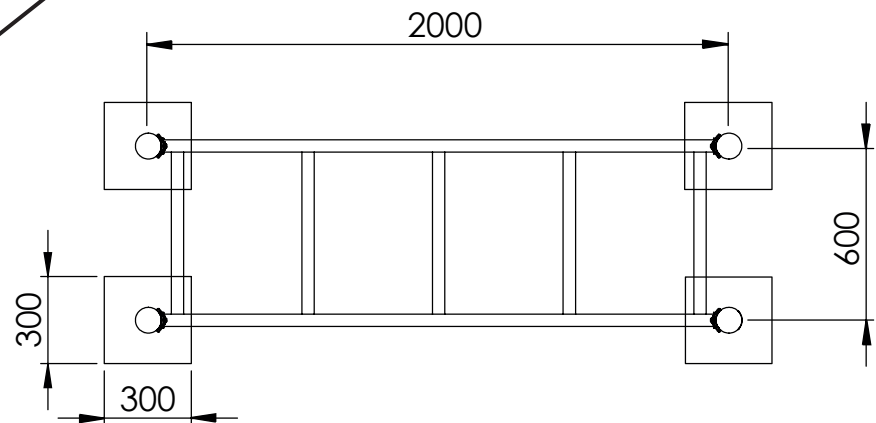

S2 (50mm) ≥C20-25
 7 x 24h
 101

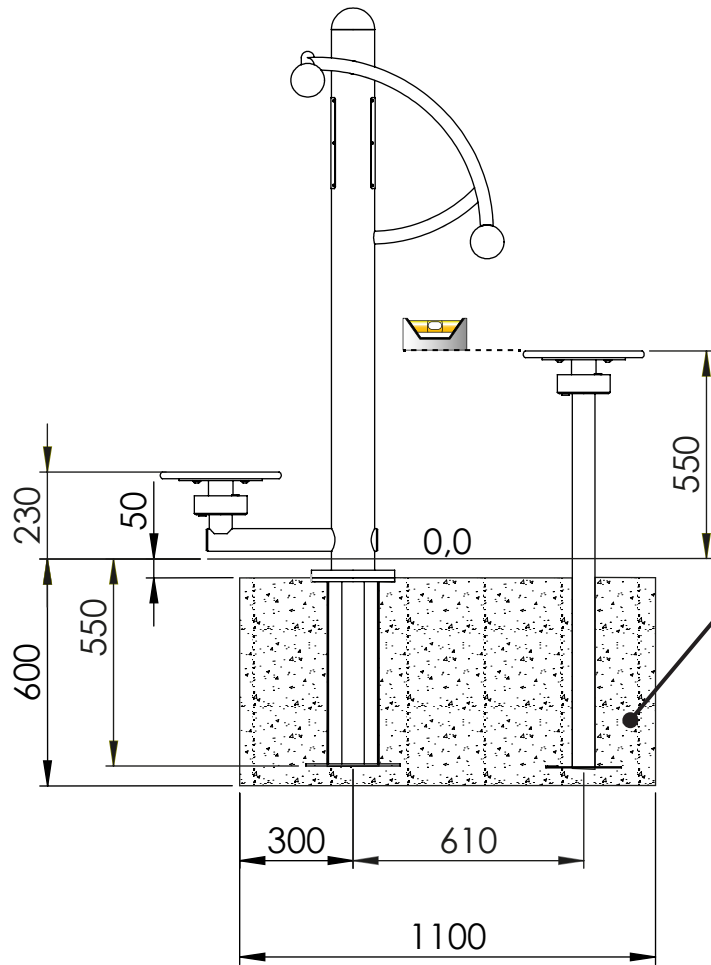

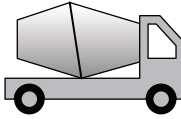
# Footing detail for FS038 Twister



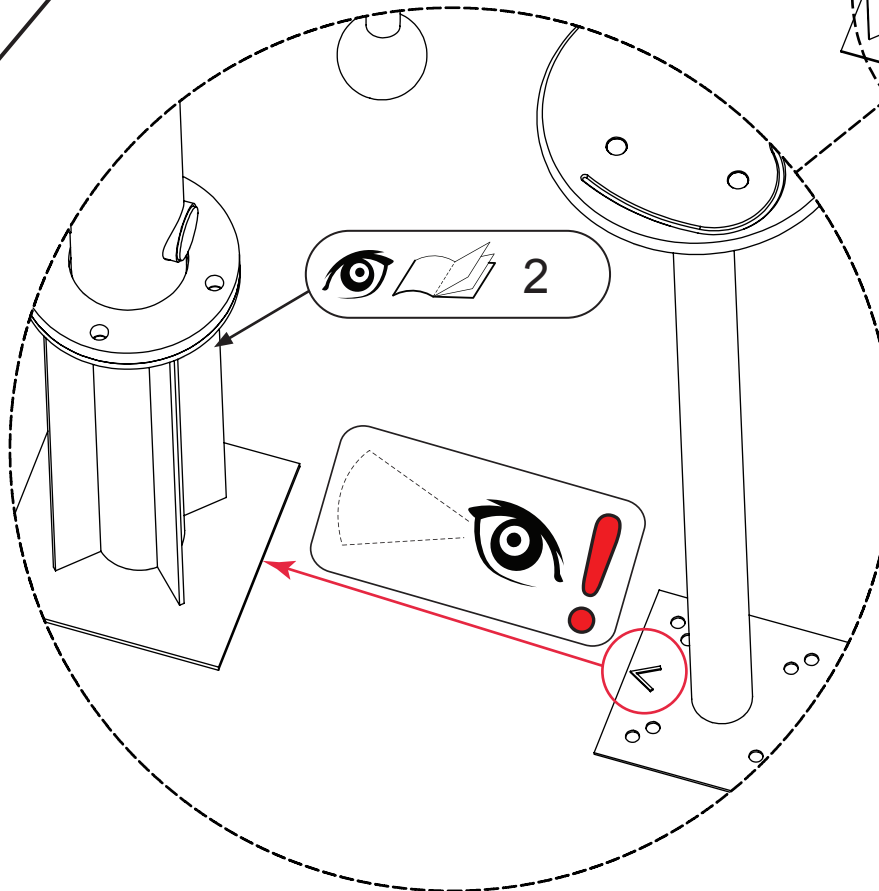
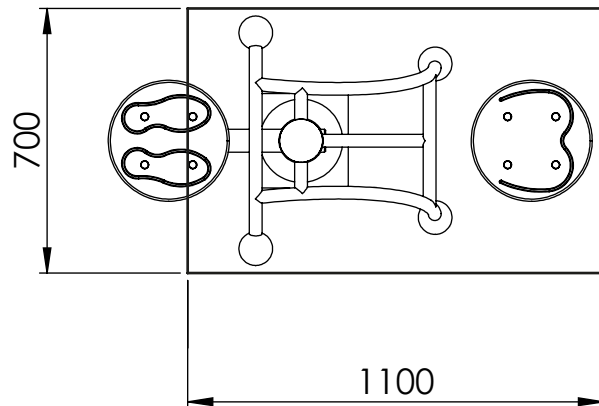
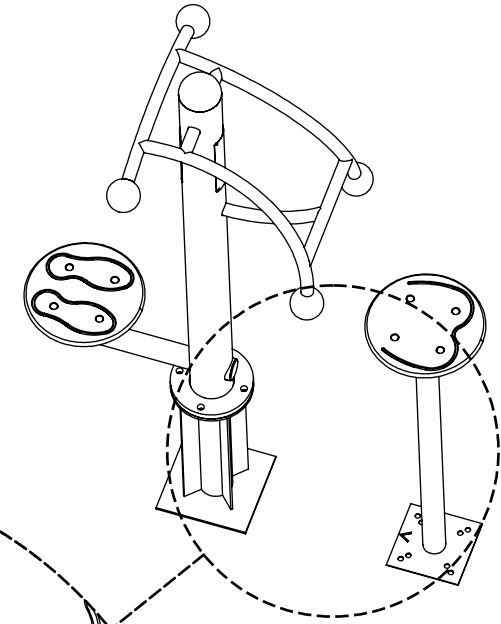

S2 (50mm) ≥C20-25
 7 x 24h
 101

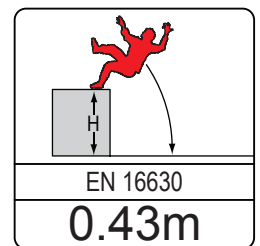
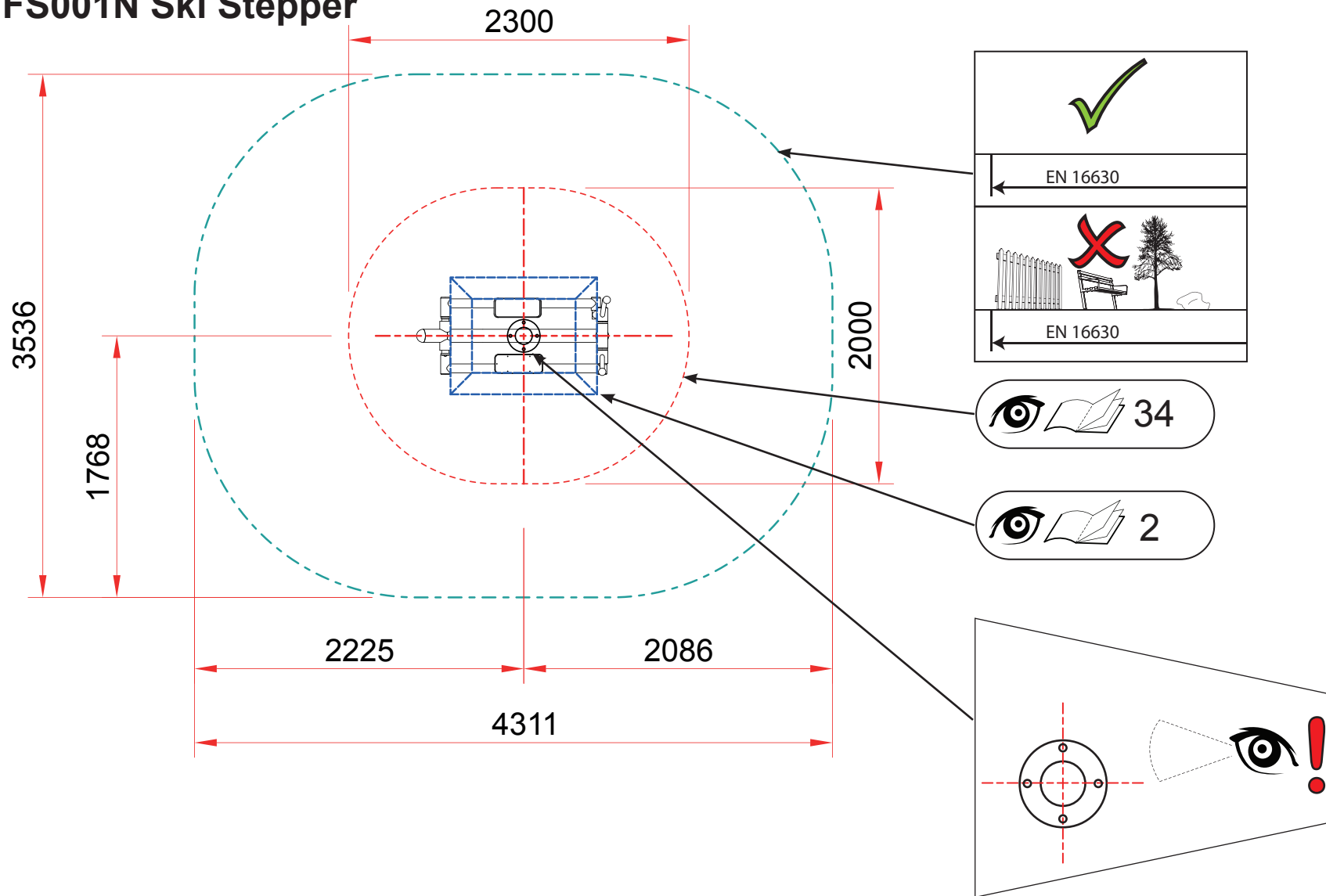

# FS001N Ski Stepper

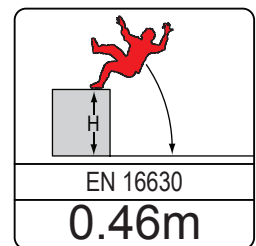
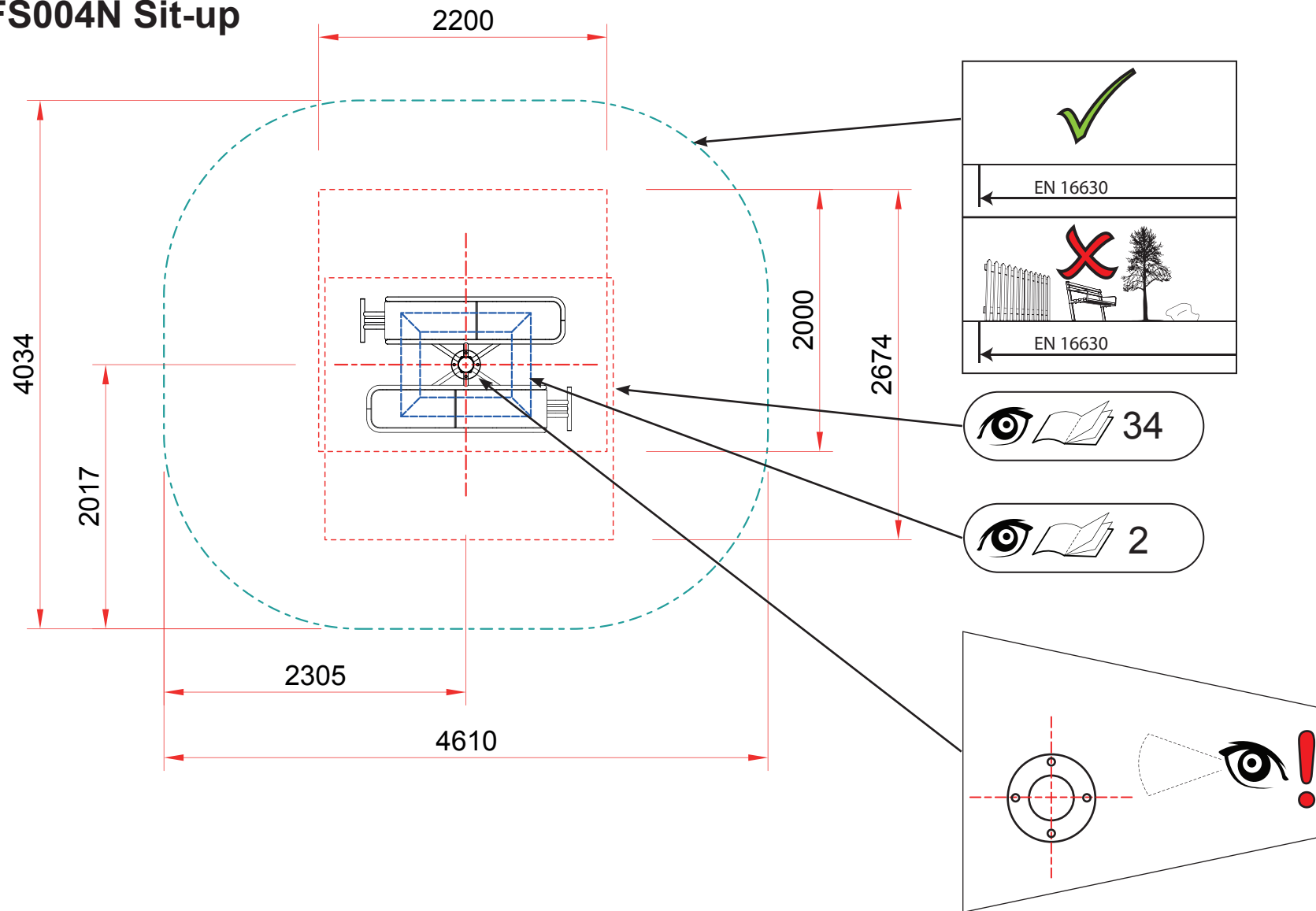

# FS004N Sit-up



# FS007N Leg Stretch

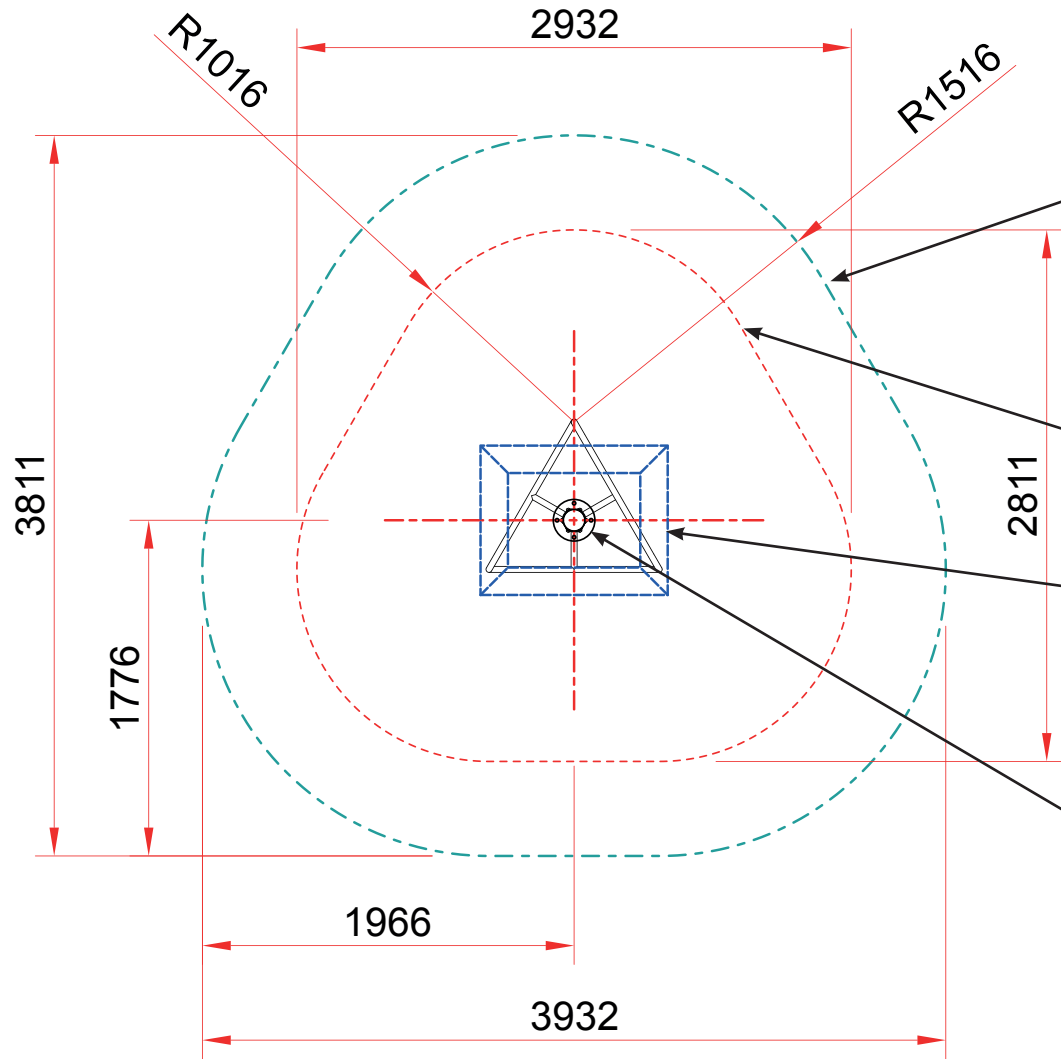

✓
← EN 16630
✗
← EN 16630

34

2

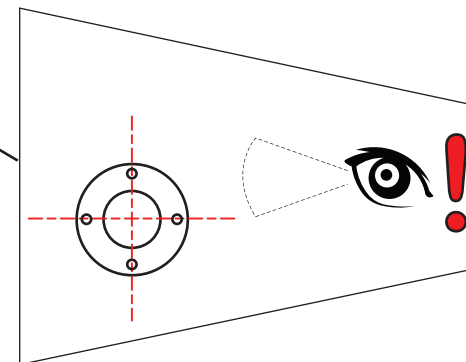

EN 16630
0m

# FS009N Parallel Rails

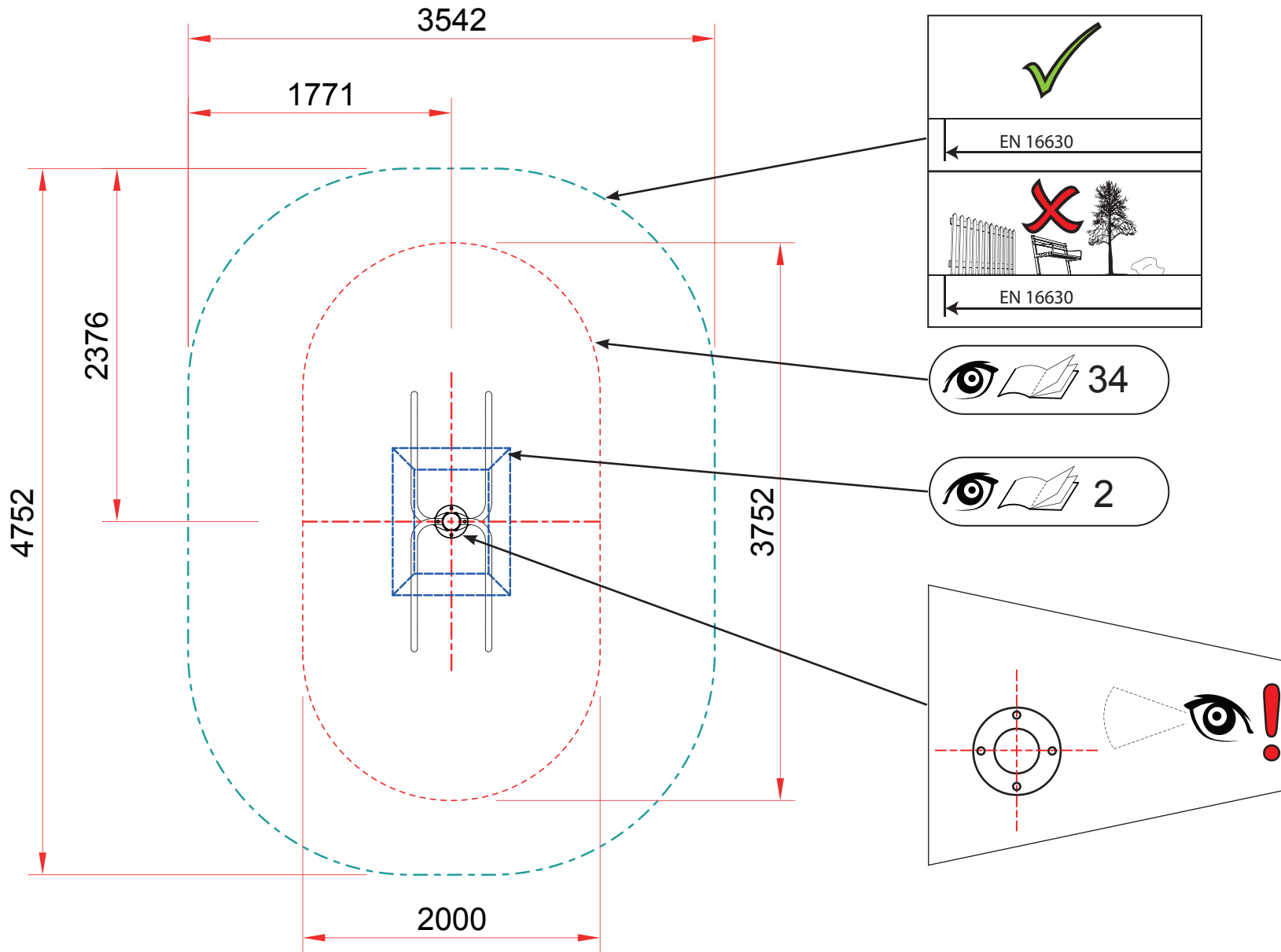

✓
← EN 16630
✗
← EN 16630

Eye icon / Book icon 34

Eye icon / Book icon 2



EN 16630
<b>1.46m</b>



# FS010N Push Hands

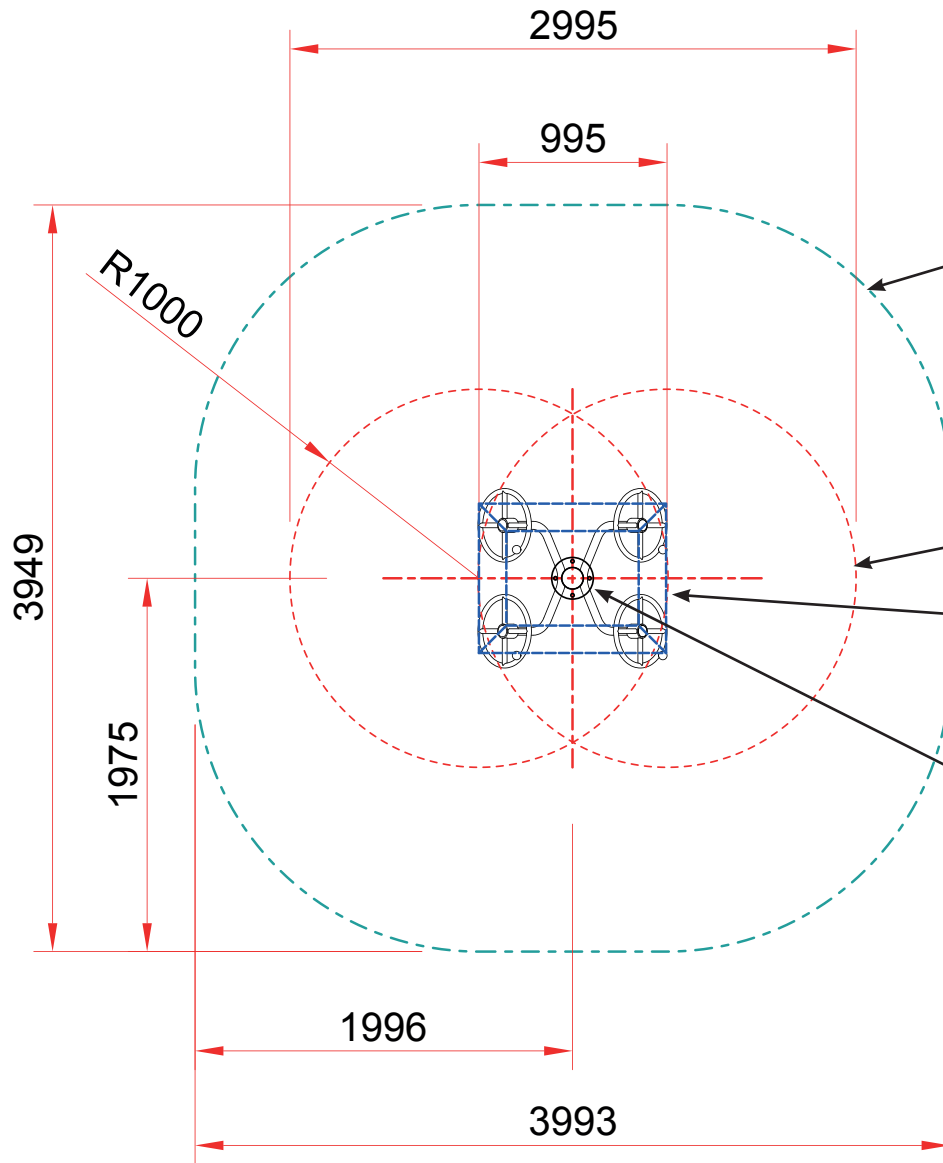

✓
← EN 16630
✗
← EN 16630



👁️ 📖 34

👁️ 📖 2

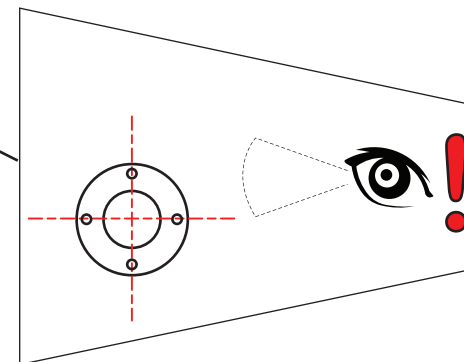

EN 16630
0m

# FS015N Pull-up

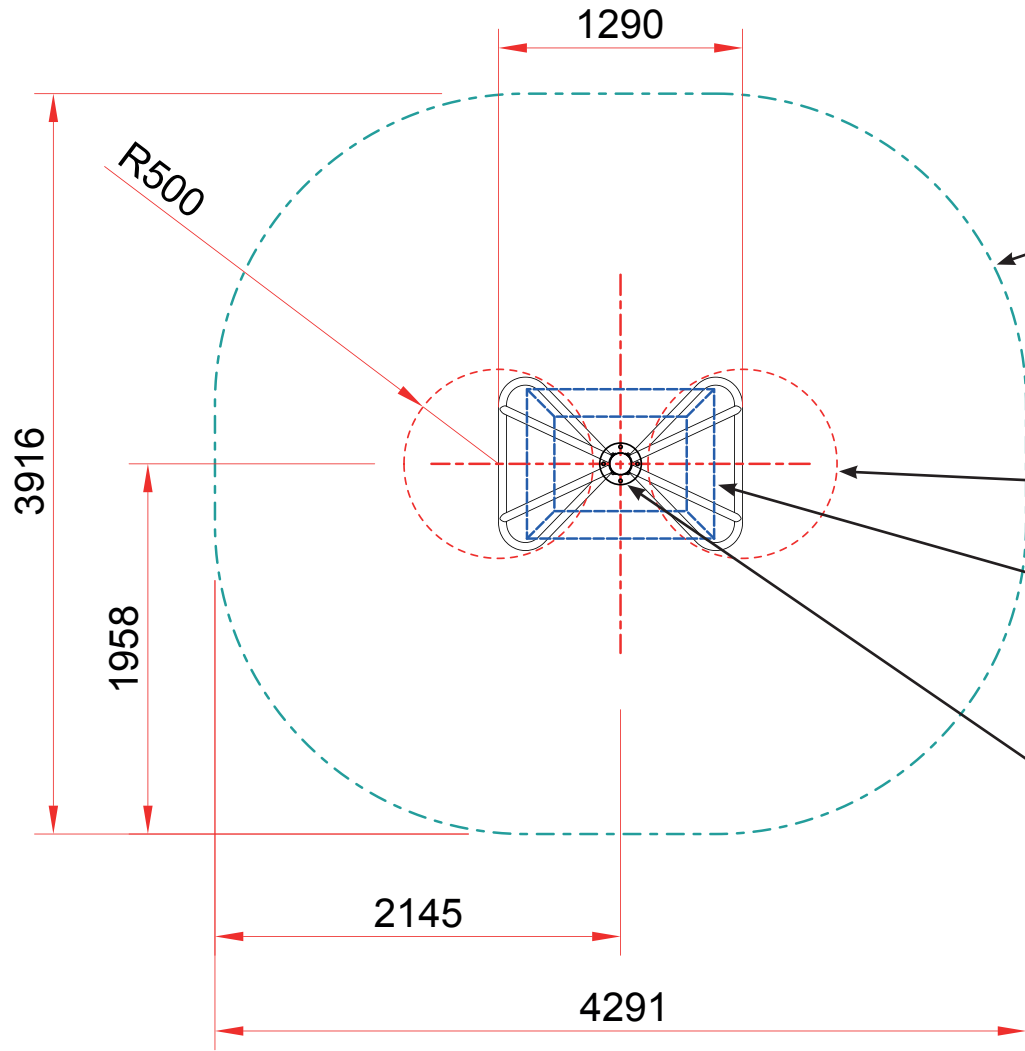

✓
← EN 16630
✗
← EN 16630

👁️ 📖 34

👁️ 📖 2

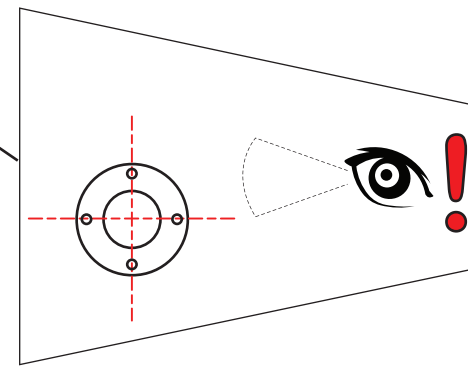

EN 16630
<b>0.87m</b>

# FS016N Trinity Cycle

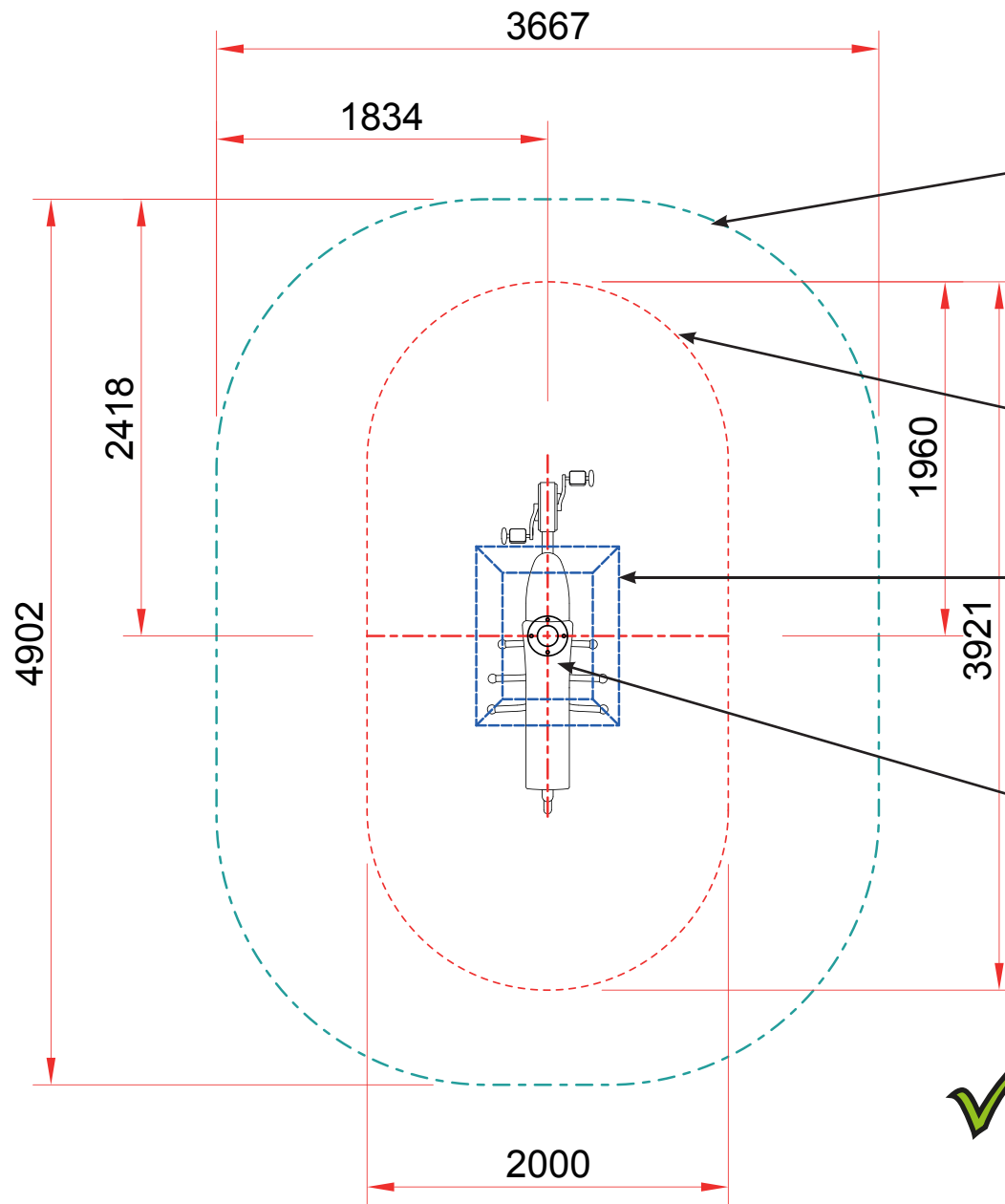

✓
← EN 16630
✗
← EN 16630



34

2

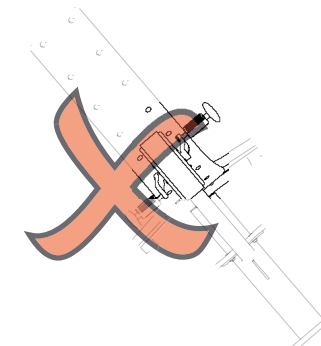
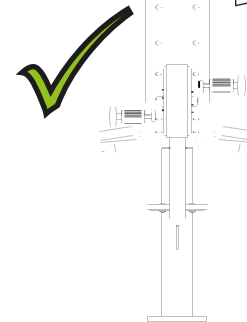
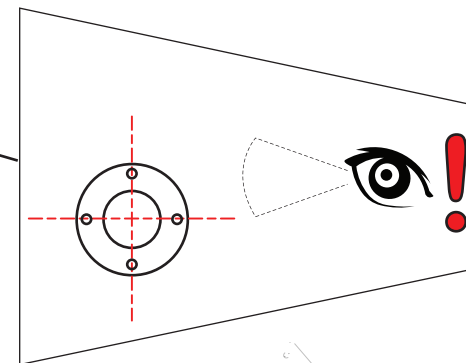

EN 16630
<b>0.94m</b>

# FS030 Air Skier

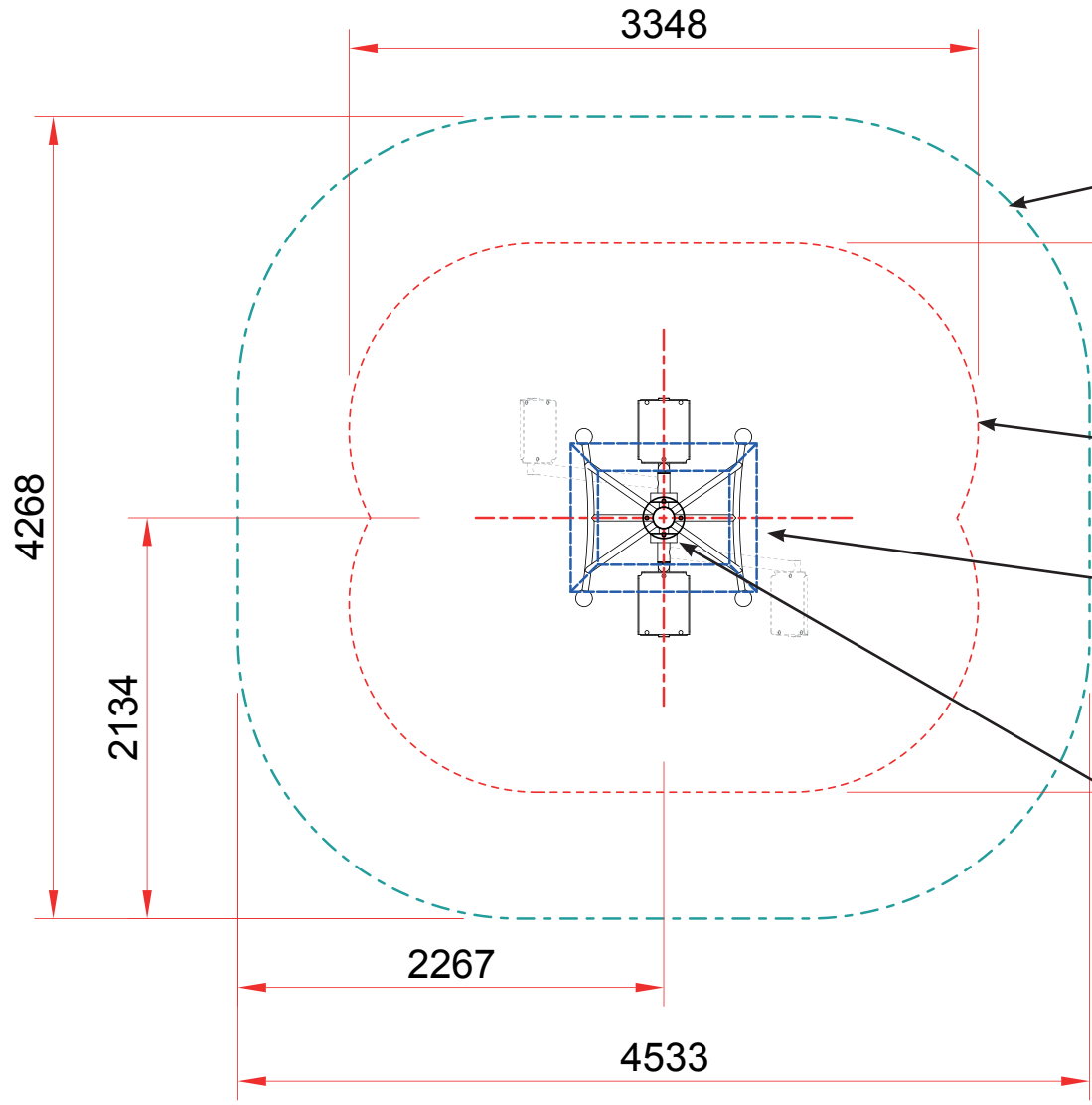

✓
← EN 16630
✗
← EN 16630



Eye icon 34

Eye icon 2

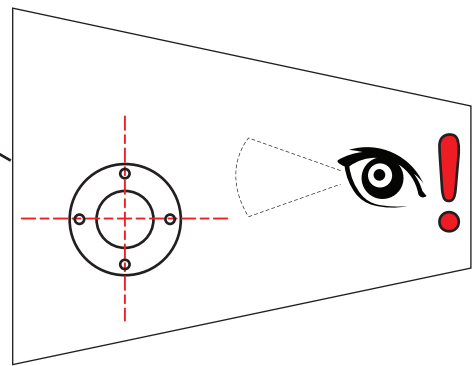

EN 16630
<b>0.48m</b>

# FS031 Air Walker

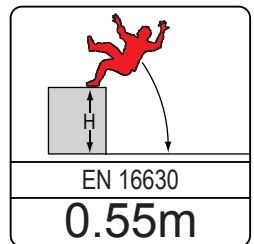
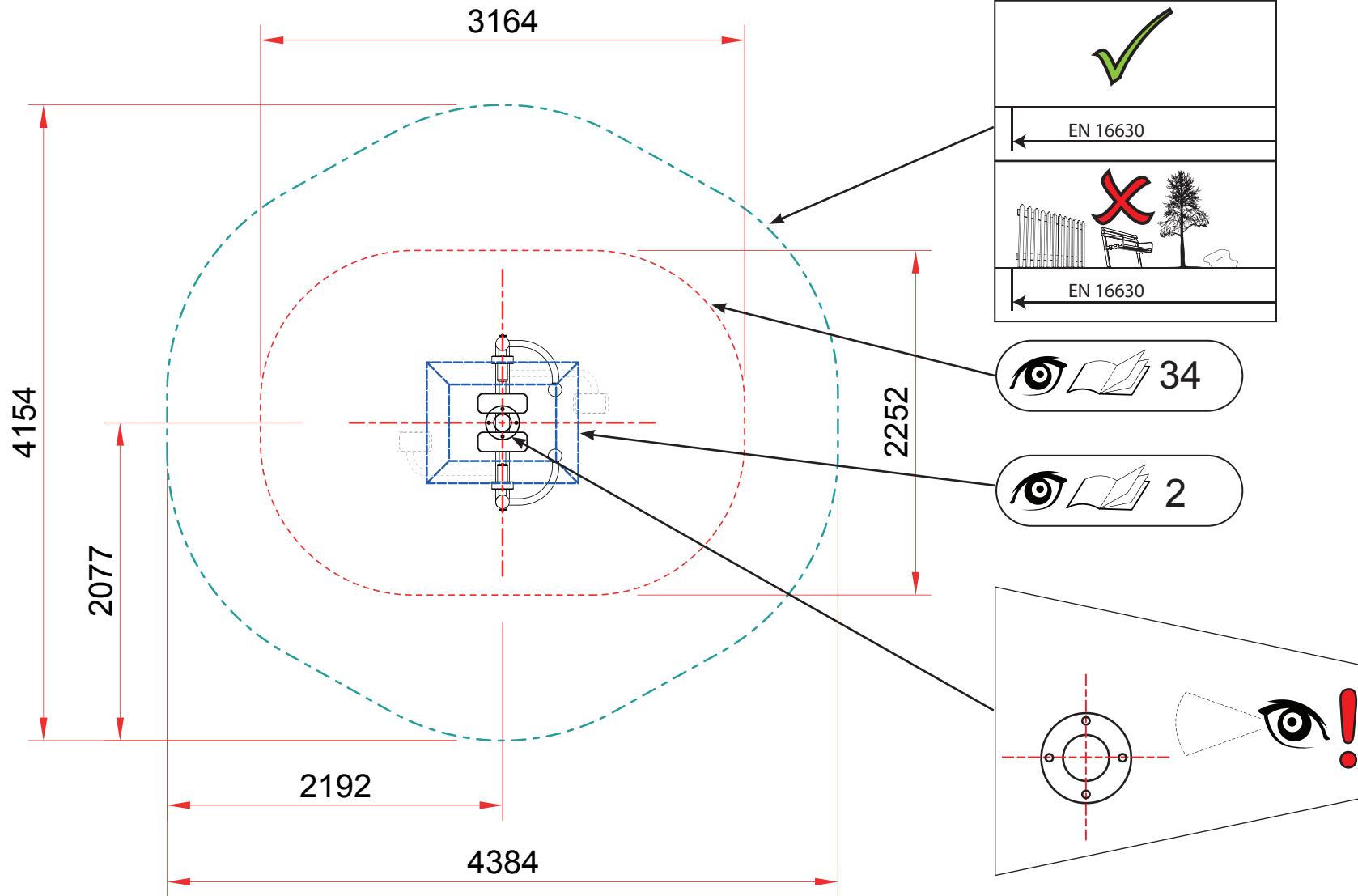

# FS032 Rower

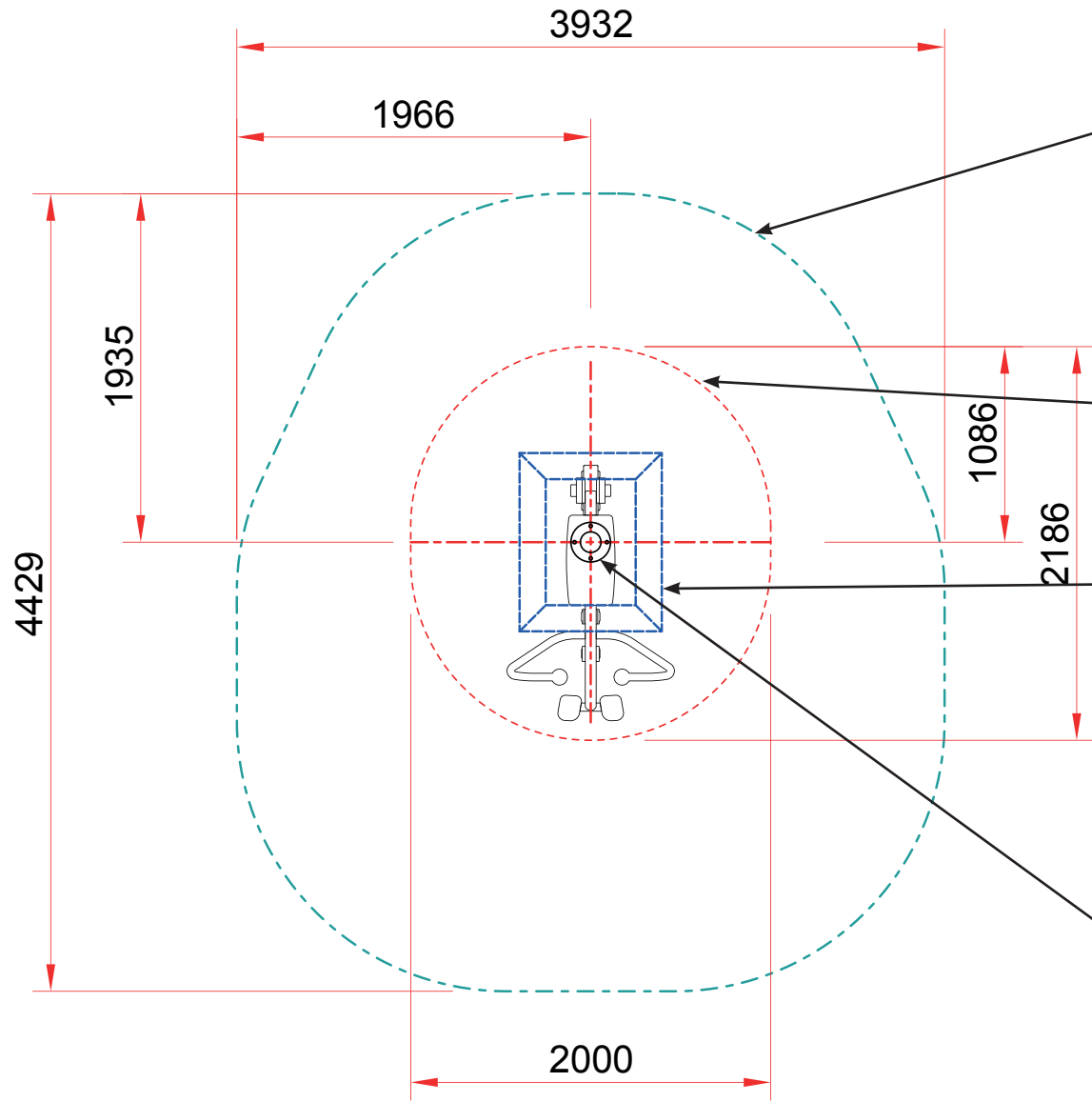

✓
← EN 16630
✗
← EN 16630



34

2

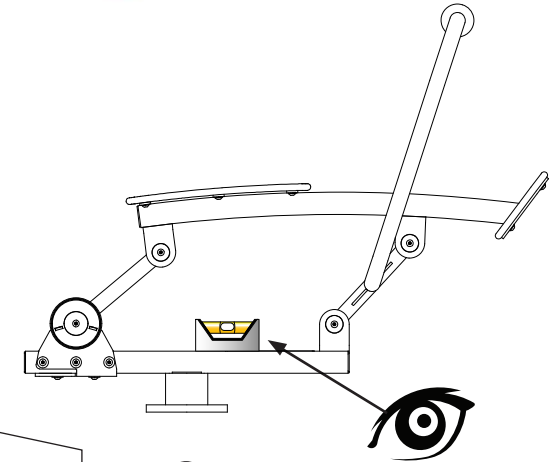
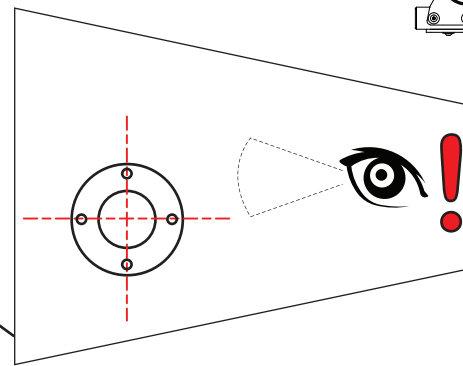

35

EN 16630
<b>0.61m</b>

# FS033 Lat Pull Down and Chest Press Combo

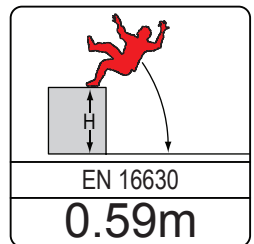
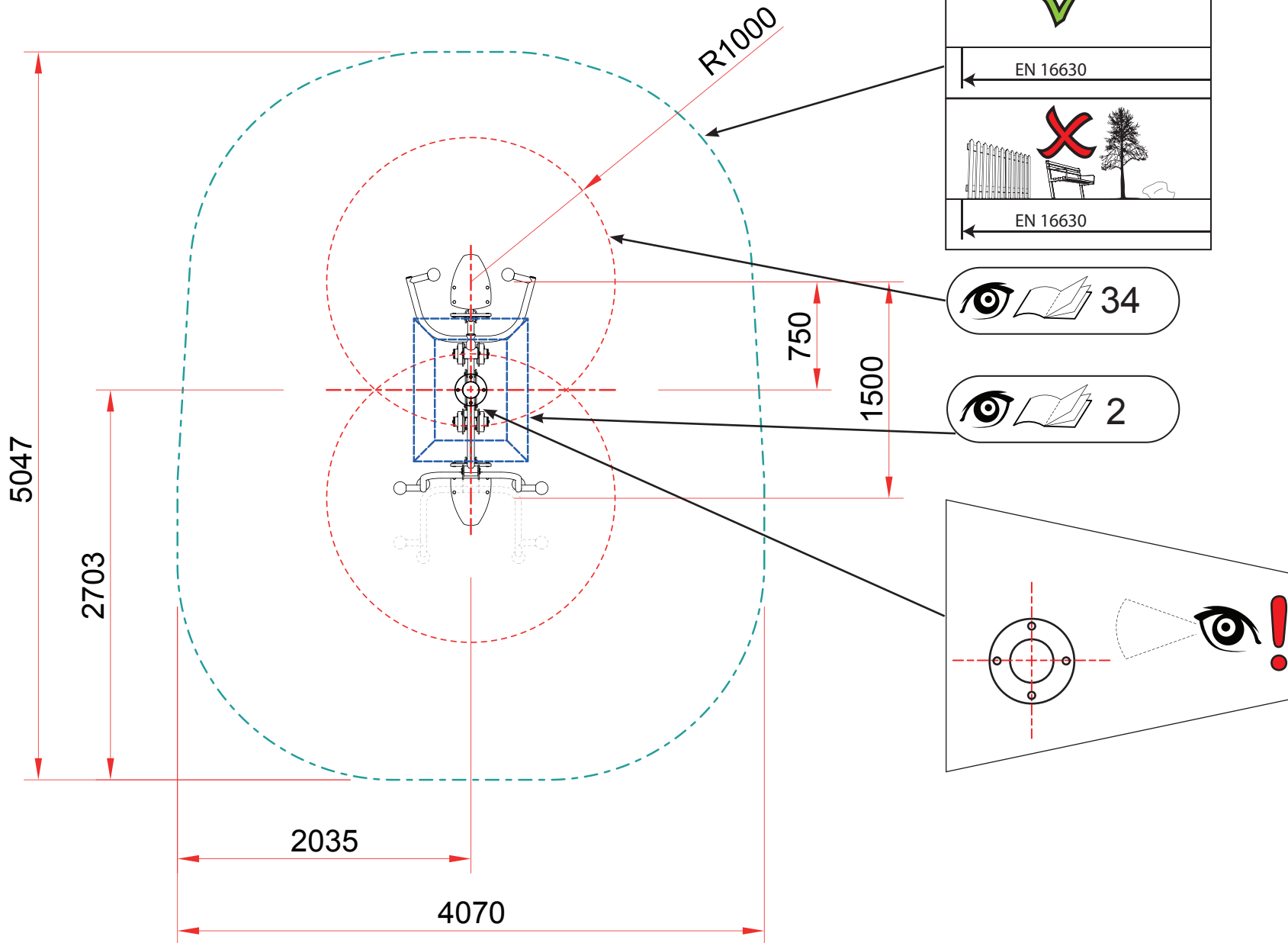

# FS034 Arm Swirl

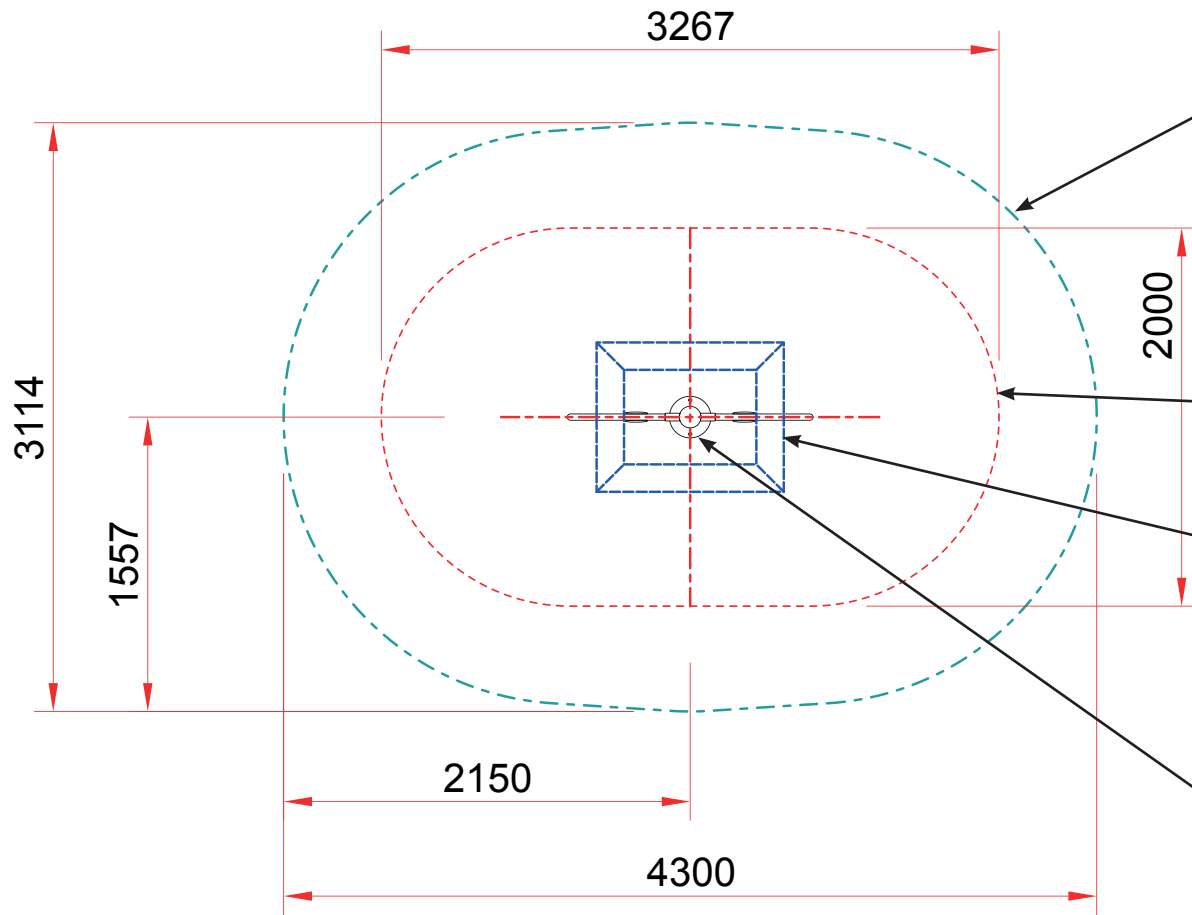

✓
← EN 16630
✗
← EN 16630

👁️ 📖 48

👁️ 📖 2

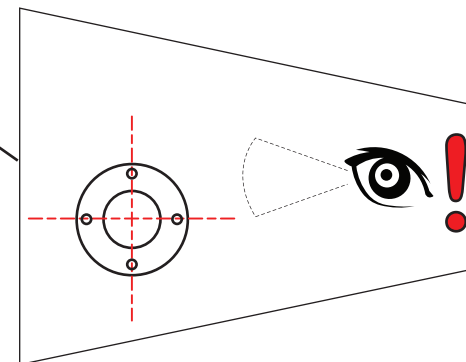

EN 16630
0m



# FS035 Step Challenge Assembly

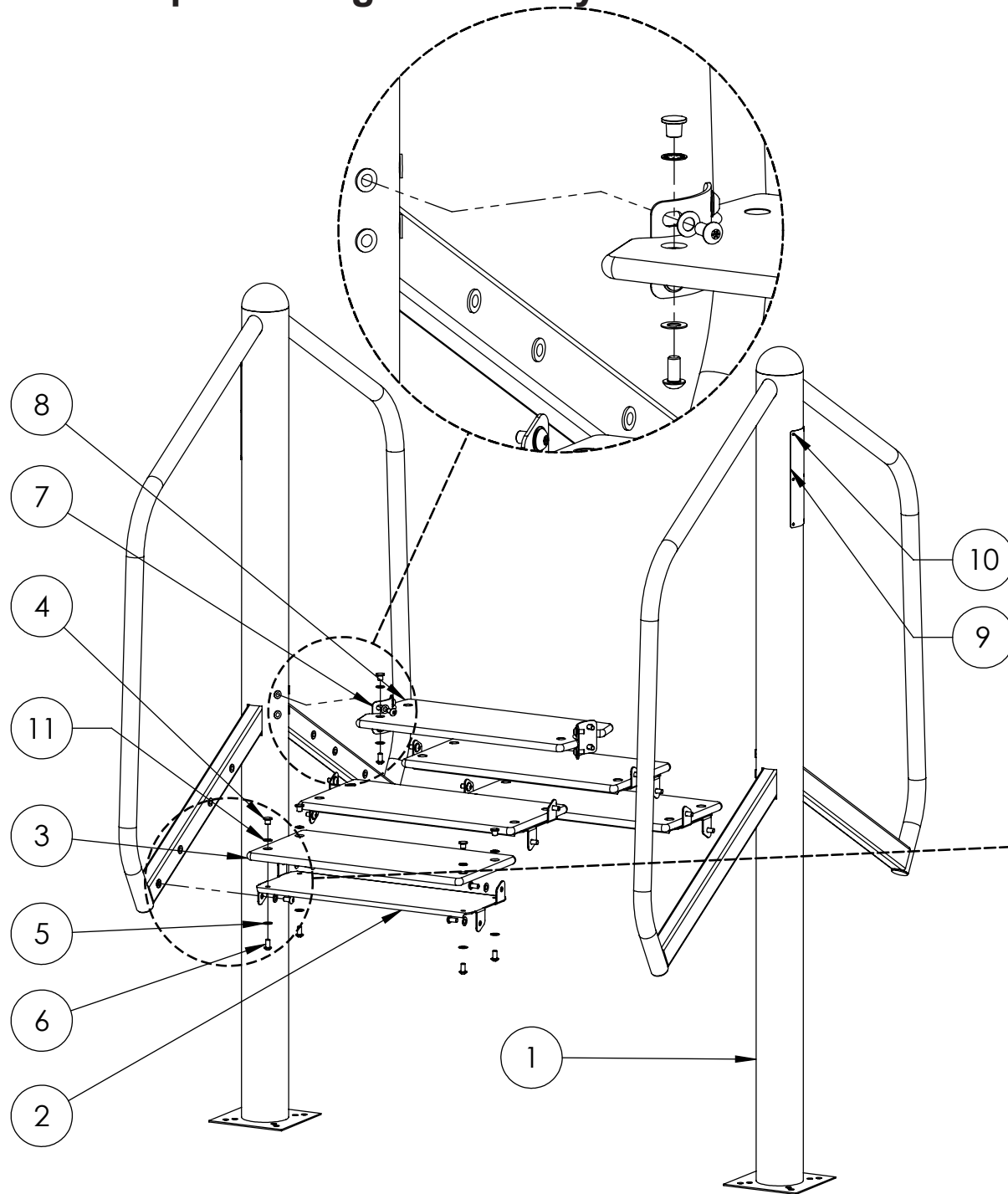

11	20	M12 INT. SH/PROOF WASHER ISO 3506 ST.ST.GRA2	10301200
10	12	4.8 x 16 ALU BLIND RIVER	10360516
9	2	Step Challenge Label	FS70000035
8	1	Step Challenge Top Step Tread	GYM1811
7	1	Step Challenge Top Tread Support	GYM1809
6	44	Raised-head screw (M10x20)	10121020
5	44	M10 Form 'B' Washer	10291000
4	20	M10 T-Nut	10931000
3	4	Step Challenge Step Tread	GYM1810
2	4	Step Challenge Tread Support	GYM1808
1	2	Step Challenge Frame Fabrication	GYM1801
Balloon	Qty	Description	Doc. ID

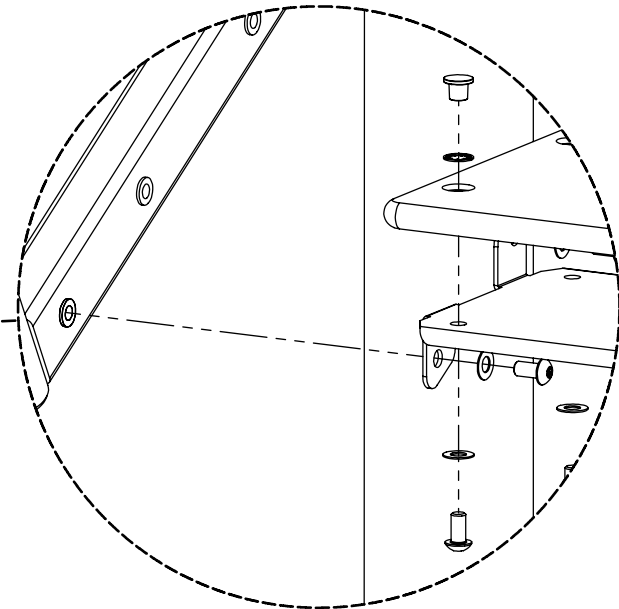

# FS035 Step Challenge

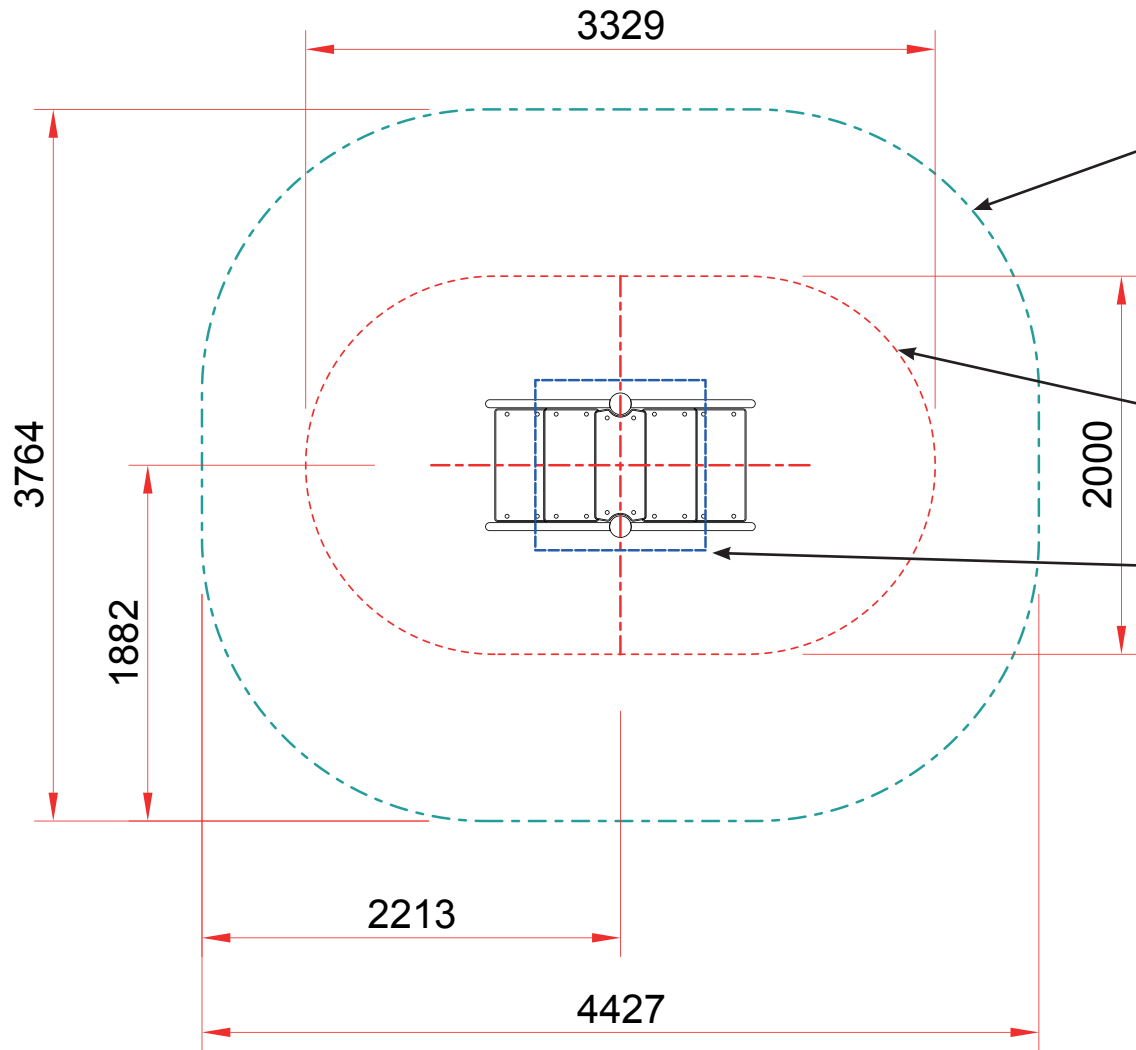

✓
← EN 16630
✗
← EN 16630



👁️ 📖 34

👁️ 📖 3

EN 16630
<b>0.45m</b>

# FS036 Finger & Arm Stretch

3253

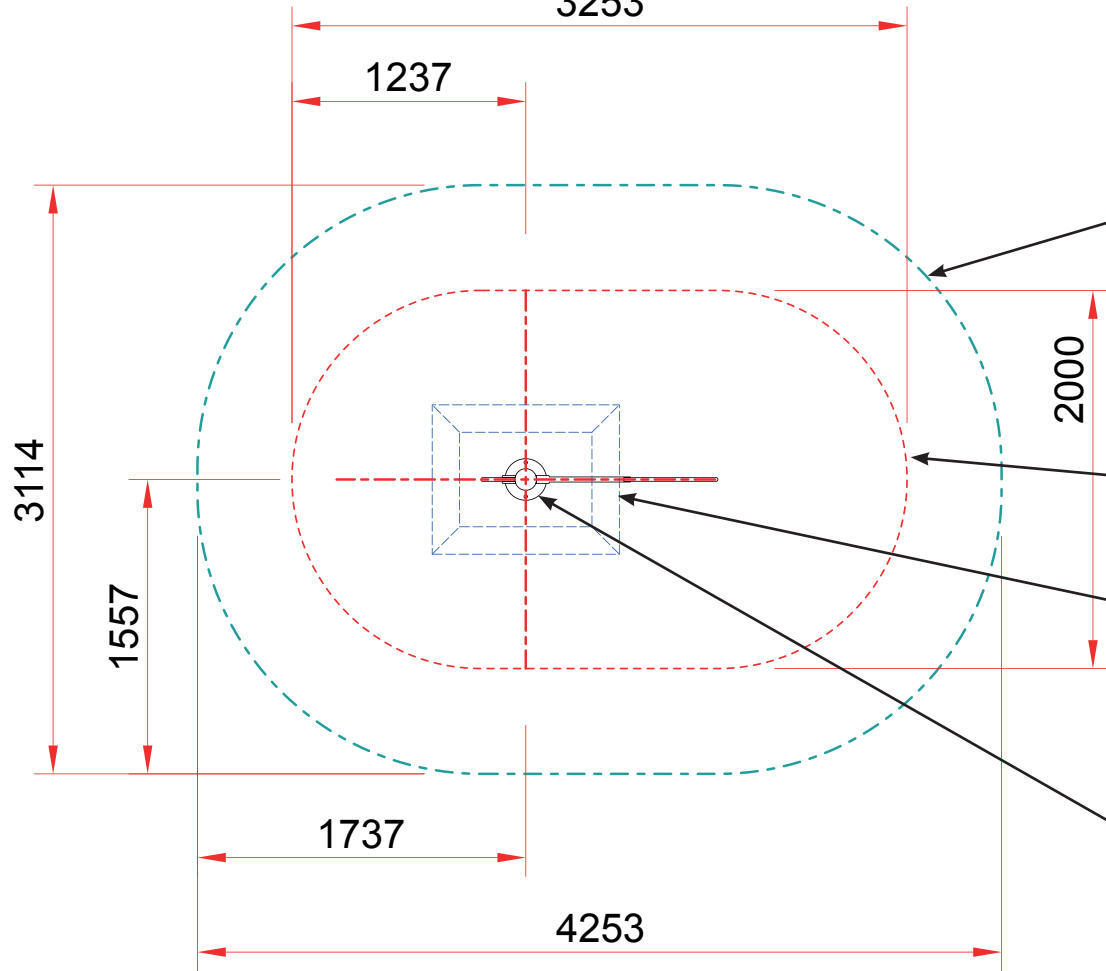

✓
← EN 16630
✗
← EN 16630

34

2

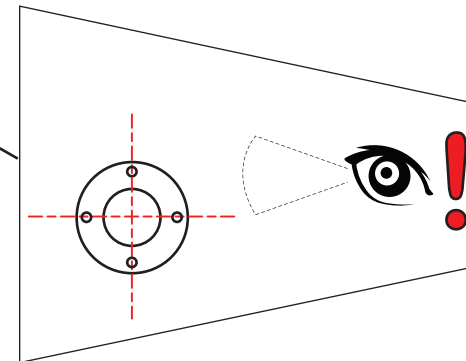

EN 16630
0m

# FS037 Ladder Walk Assembly

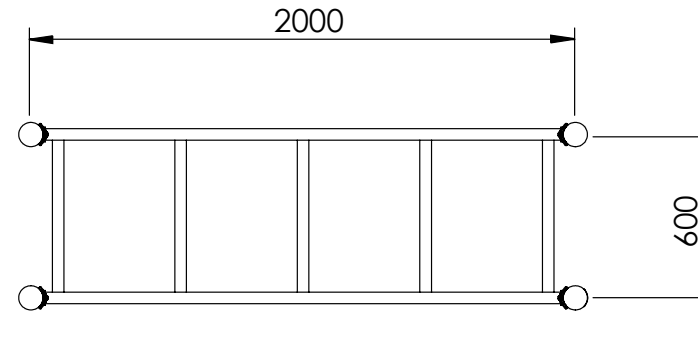
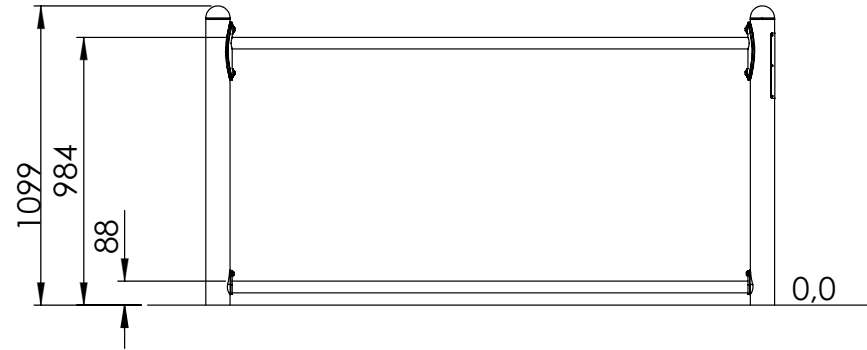
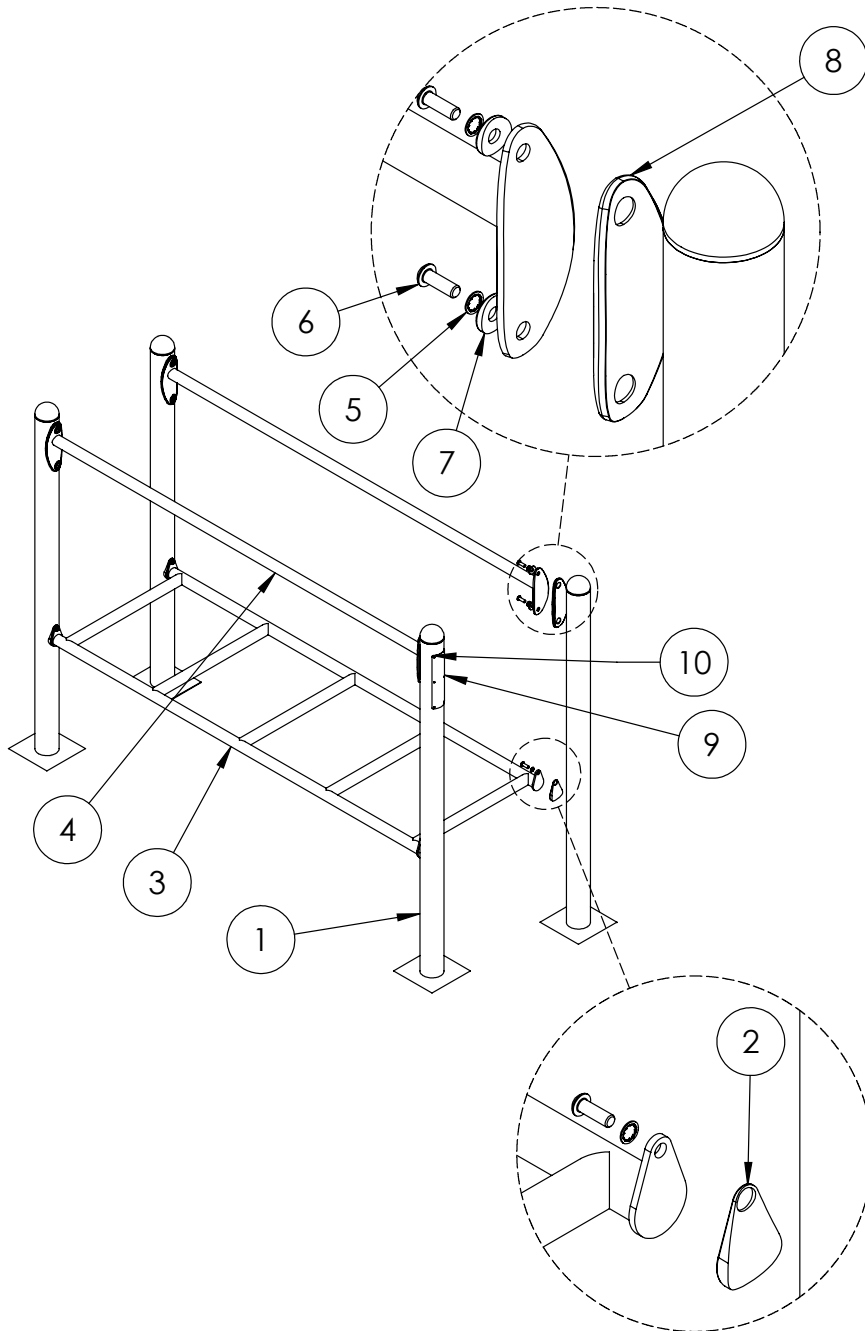

10	6	4.8 x 16 ALU BLIND RIVET	10360516
9	1	Ladder Walk Label	FS70000037
8	4	Tower Gasket Ø88.9	19023802
7	8	M10 SADDLE WASHER	38001019
6	12	Raised-head screw (M10x30)	10121030
5	12	M10-WASHER SH-PROOF	10301000
4	2	Ladder Walk Handrail	GYM2003
3	1	Ladder Walk Rungs	GYM2002
2	4	Sports Fixing Spacer	19025501
1	4	Ladder Walk Post	GYM2001
Balloon	Qty	Description	Doc. ID

# FS037 Ladder Walk

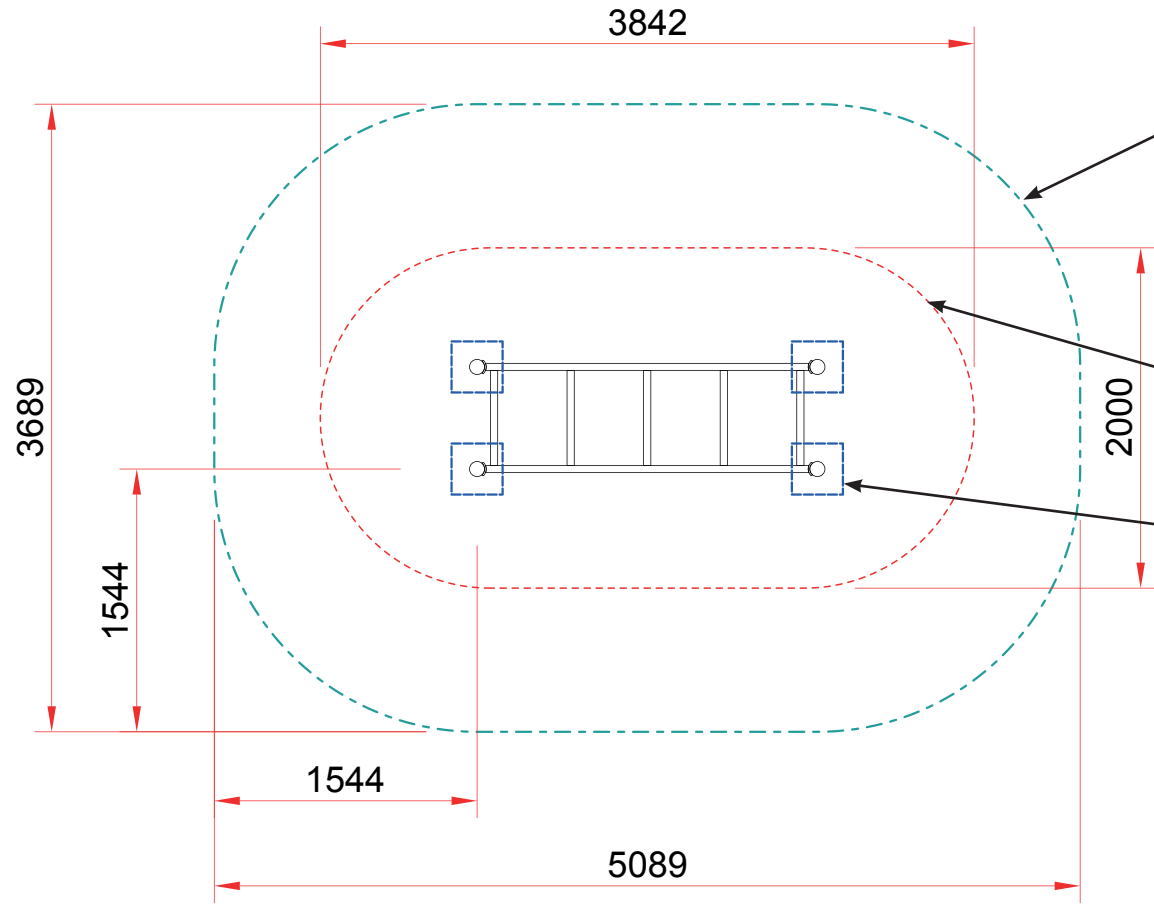

✓
← EN 16630
✗
← EN 16630

👁️ 📖 34

👁️ 📖 3





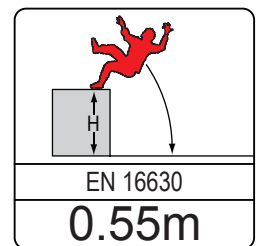
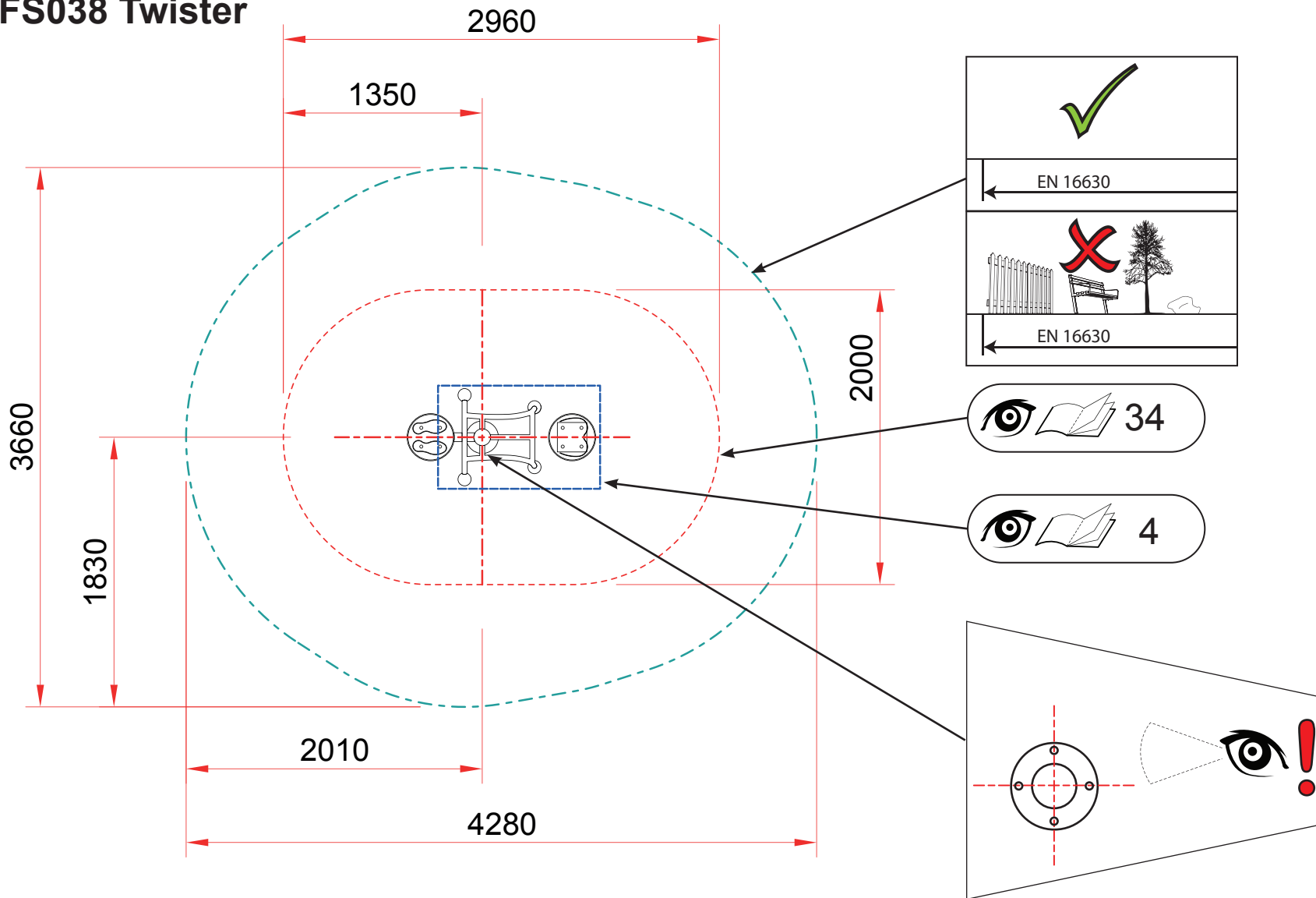

EN 16630  
0.1m

# FS038 Twister

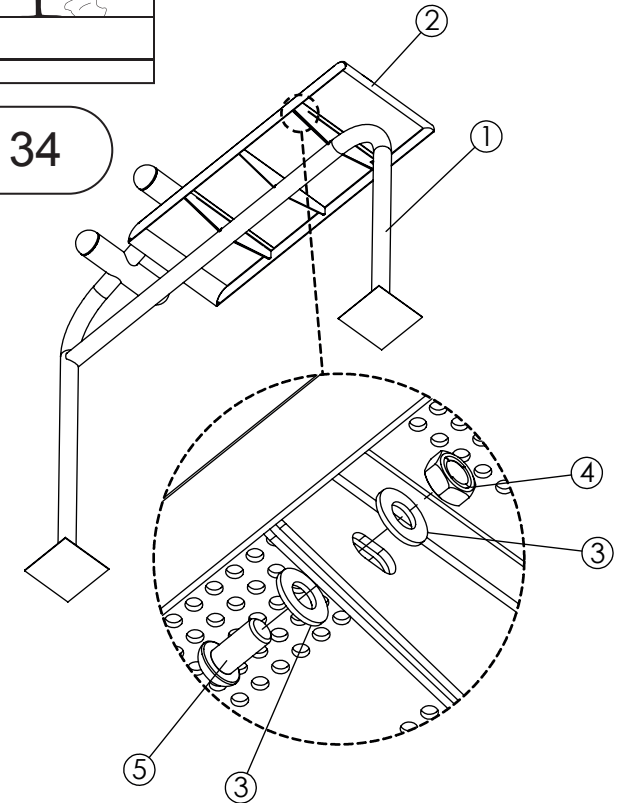
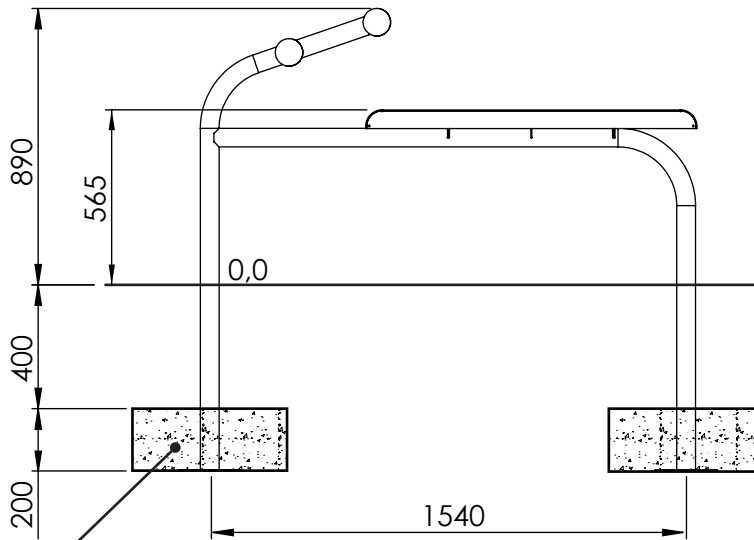
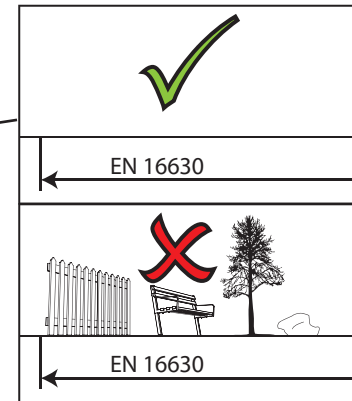
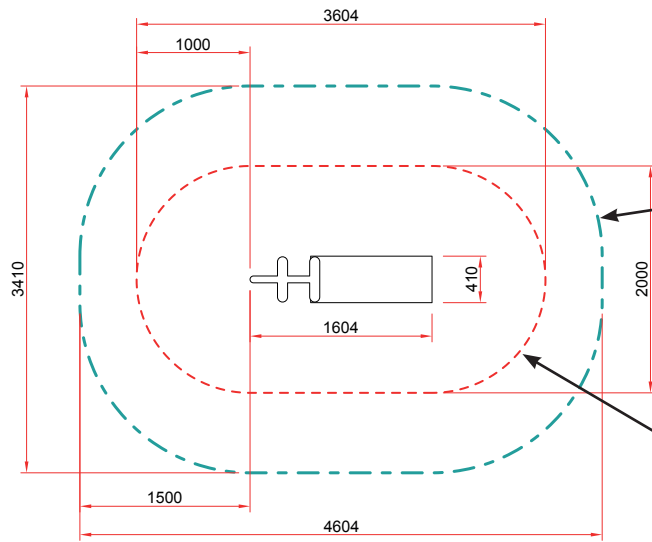

# FS100 Sit-up



  
**S2 (50mm)**  
**≥C20-25**  
 **7 x 24h**  
 **101**

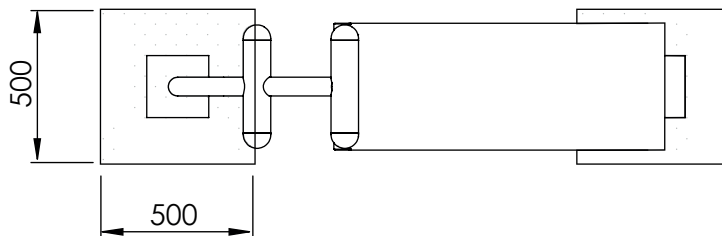

Key	Art No	Description	Qty
1	GYM500	Sit-up Frame	1
2	8038124	Large Seat	1
3	10291000	M10 Washer	8
4	10261000	M10 Nyloc Nut	4
5	10121030	M10 x 30 Resistorx	4

  
**EN 16630**  
**0.89m**

# FS101 Body Curl

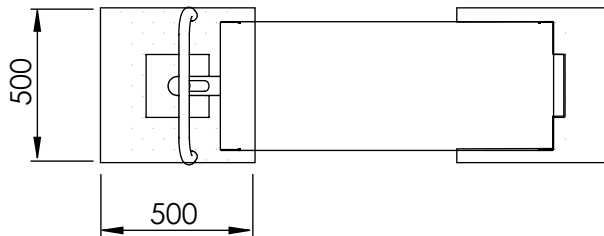
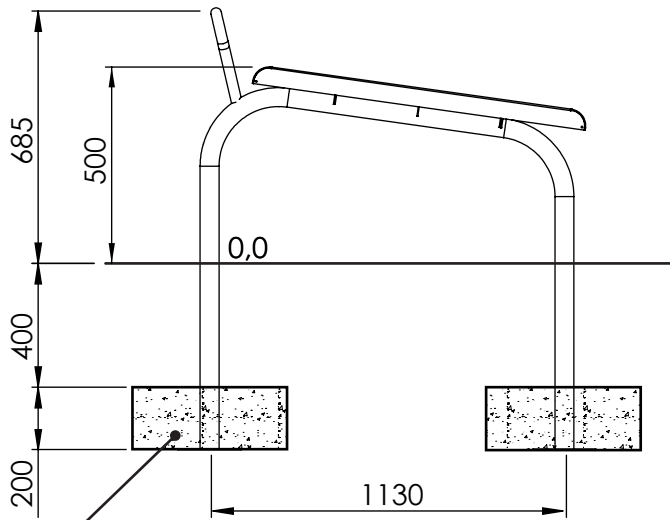
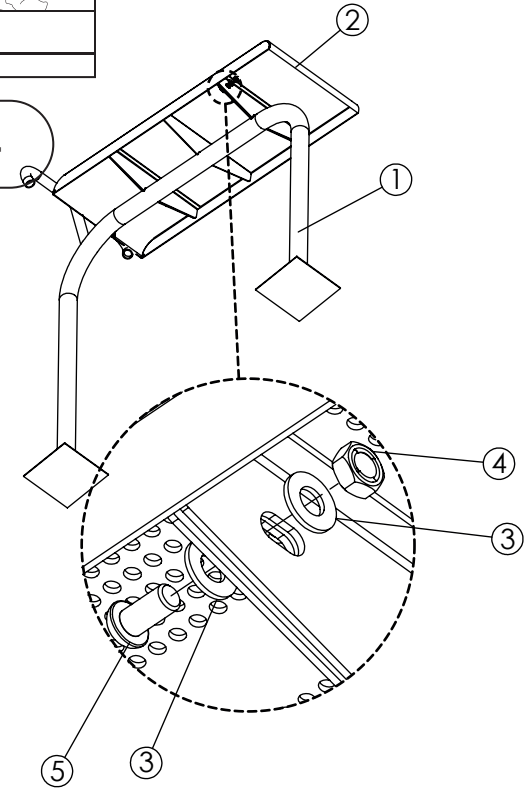
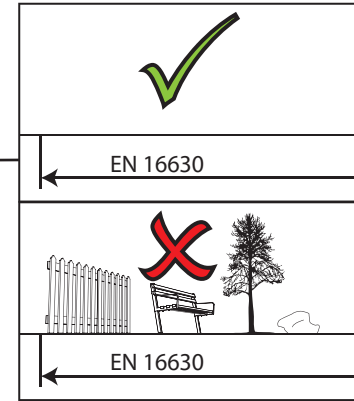
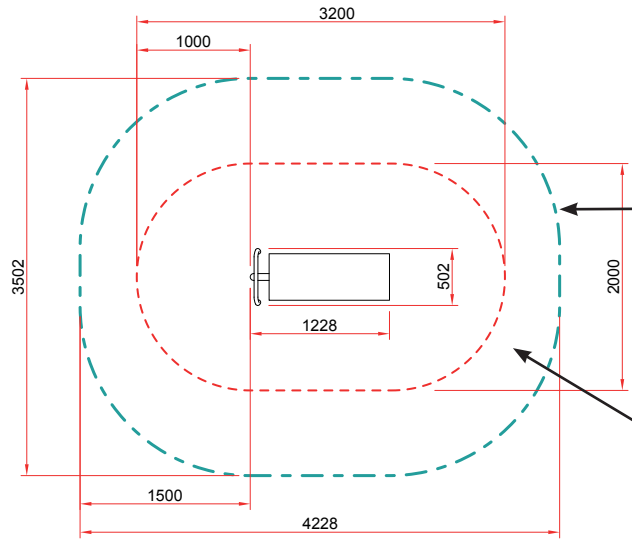



S2 (50mm)  
≥C20-25



7 x 24h



101

Key	Art No	Description	Qty
1	GYM501	Body Curl Frame	1
2	8038124	Large Seat	1
3	10291000	M10 Washer	8
4	10261000	M10 Nyloc Nut	4
5	10121030	M10 x 30 Resistorx	4



EN 16630

**0.69m**



# FS102 Balance Beam

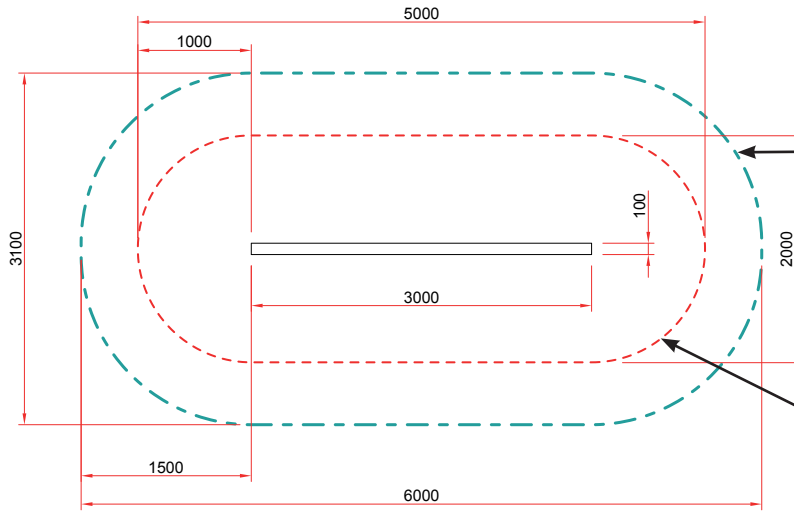

✓
← EN 16630
✗
← EN 16630

34

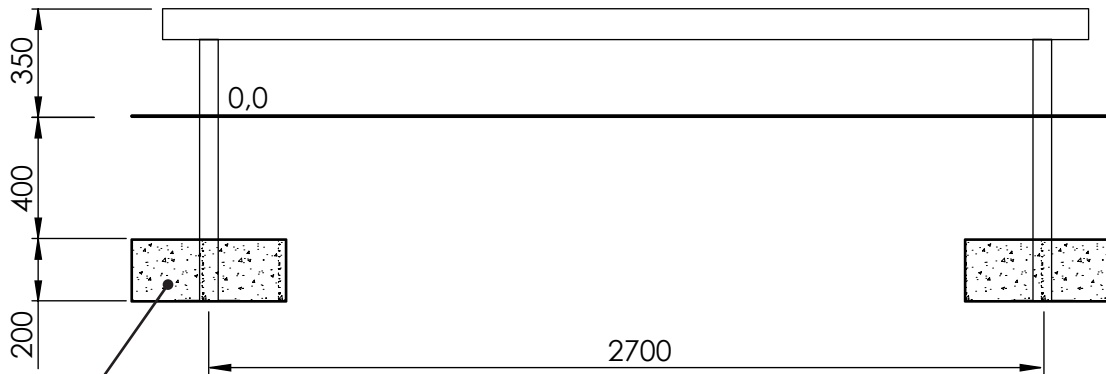
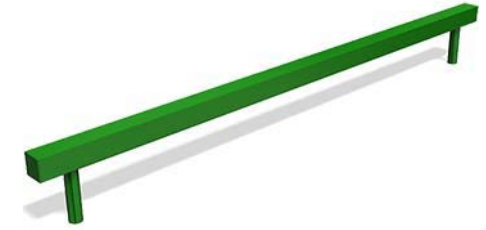

S2 (50mm) ≥C20-25
7 x 24h
101



EN 16630
0.35m

# FS102 Beam Jump

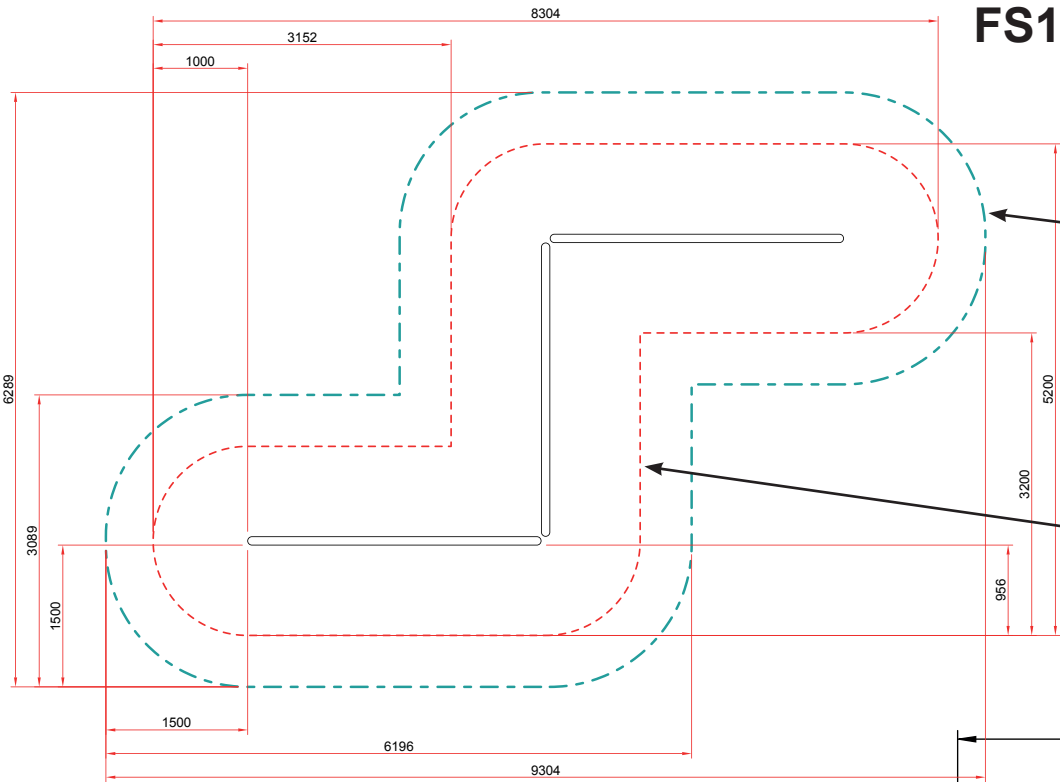

✓
← EN 16630
✗
← EN 16630

34

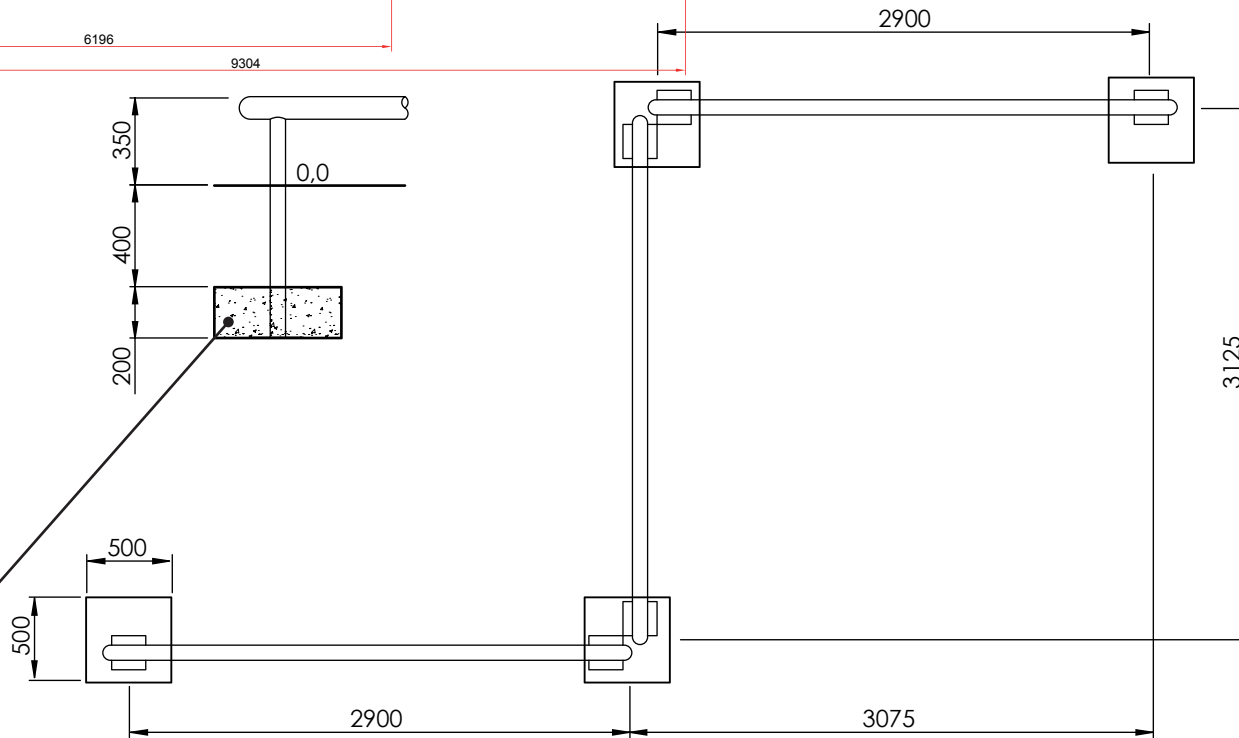
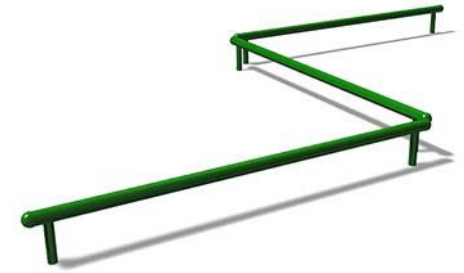



S2 (50mm) ≥C20-25
7 x 24h
101

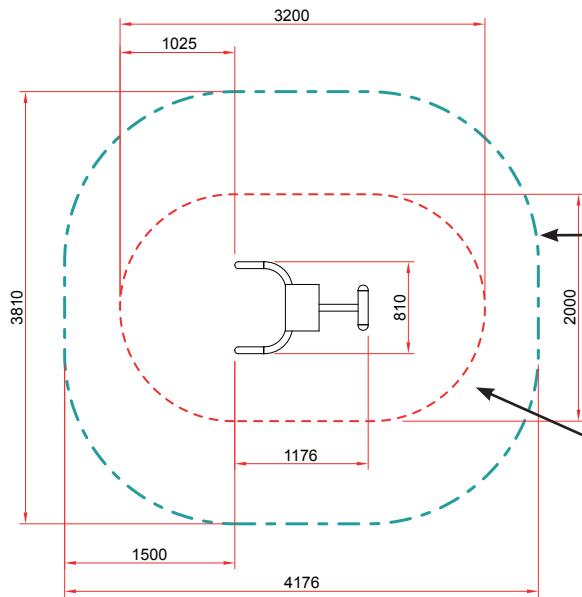

EN 16630
0.35m

# FS104 Hyper-Extension Bench





  
 EN 16630  
  
 EN 16630



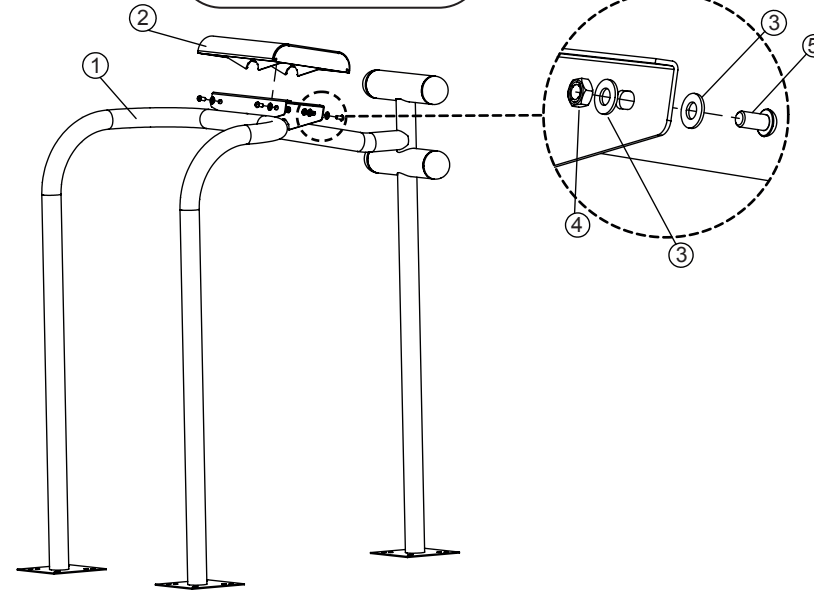
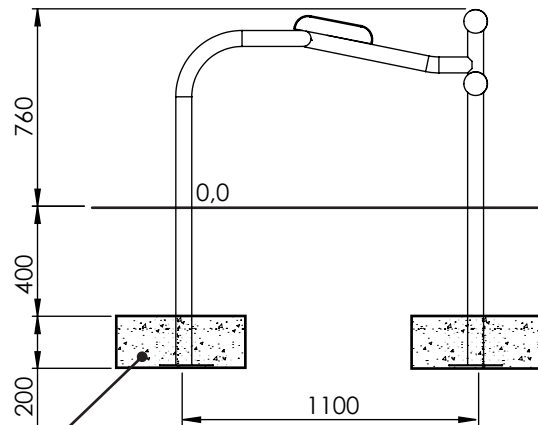

**34**

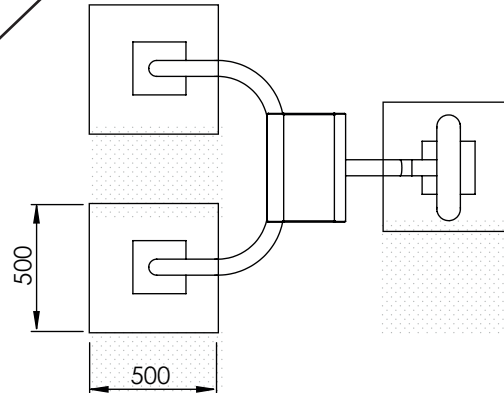

  
 S2 (50mm)  
 ≥C20-25  
 7 x 24h  
 **101**

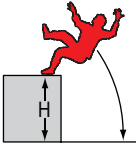

Key	Art No	Description	Qty
1	GYM504	Hyperextension Frame	1
2	8038197	Small Seat	1
3	10291000	M10 Washer	8
4	10261000	M10 Nyloc Nut	4
5	10121030	M10 x 30 Resistorx	4

  
 EN 16630  
**0.76m**

# FS105 Push Up

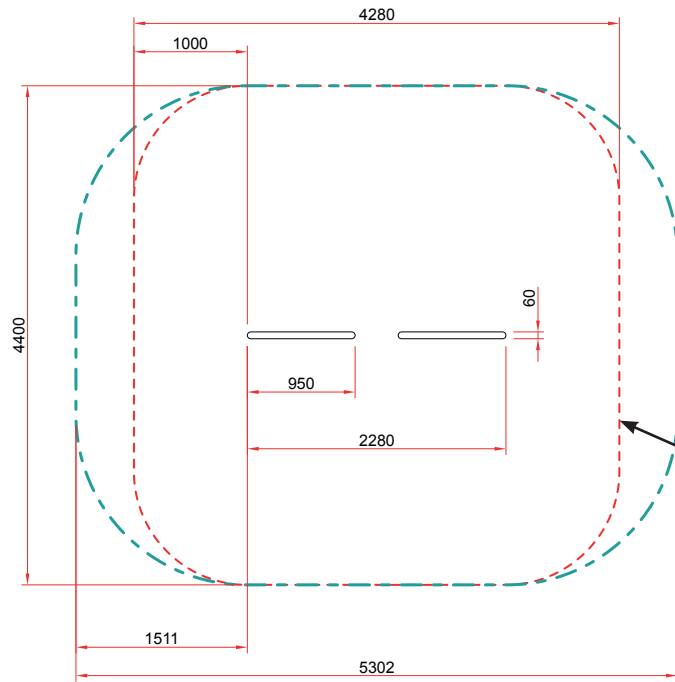

✓
← EN 16630
✗
← EN 16630

34

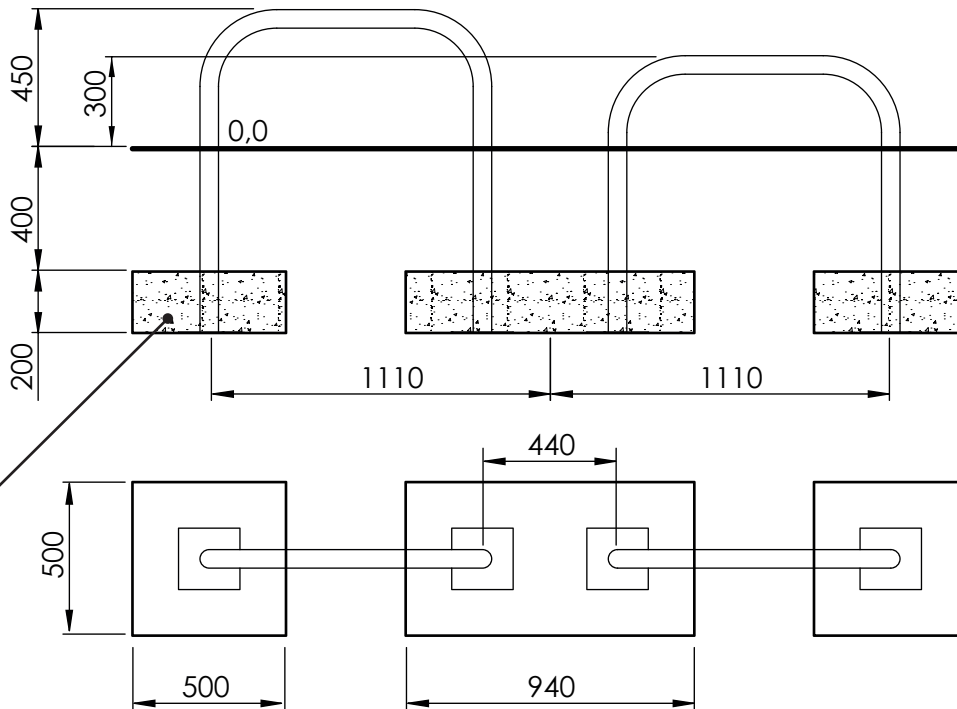
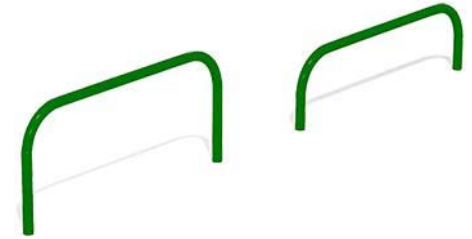



S2 (50mm) ≥C20-25
7 x 24h
101

EN 16630
0.45m

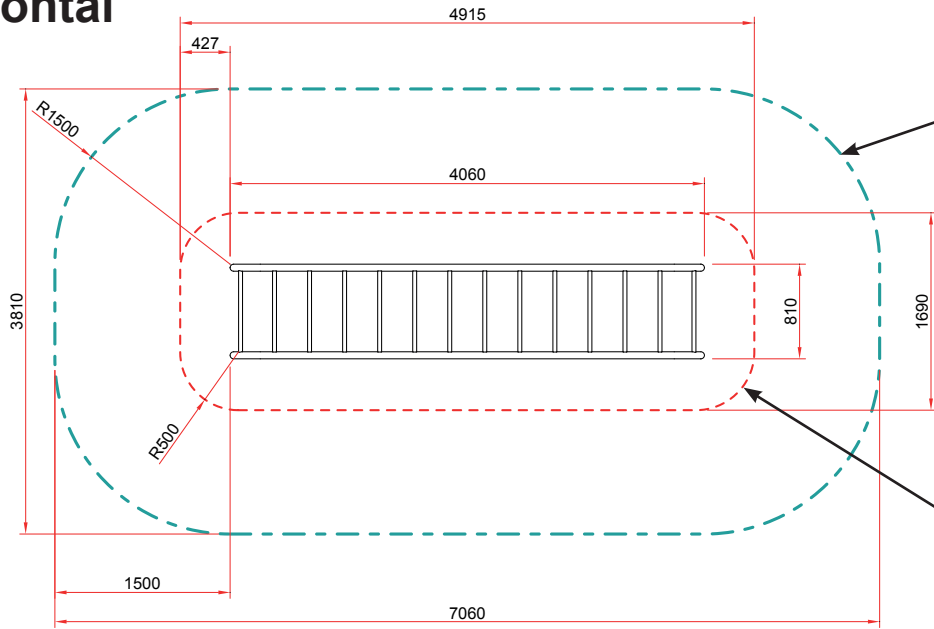
# FS106 Horizontal Ladder



  
 EN 16630

  
 EN 16630





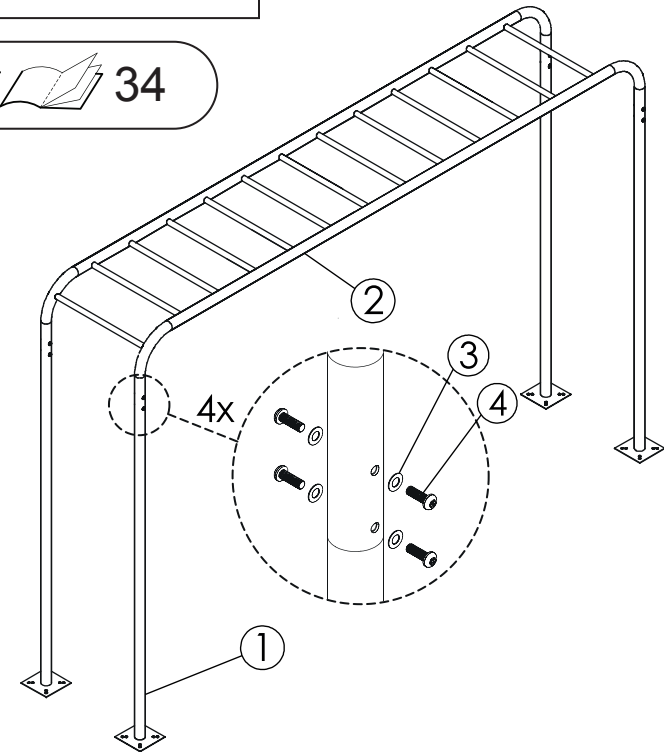
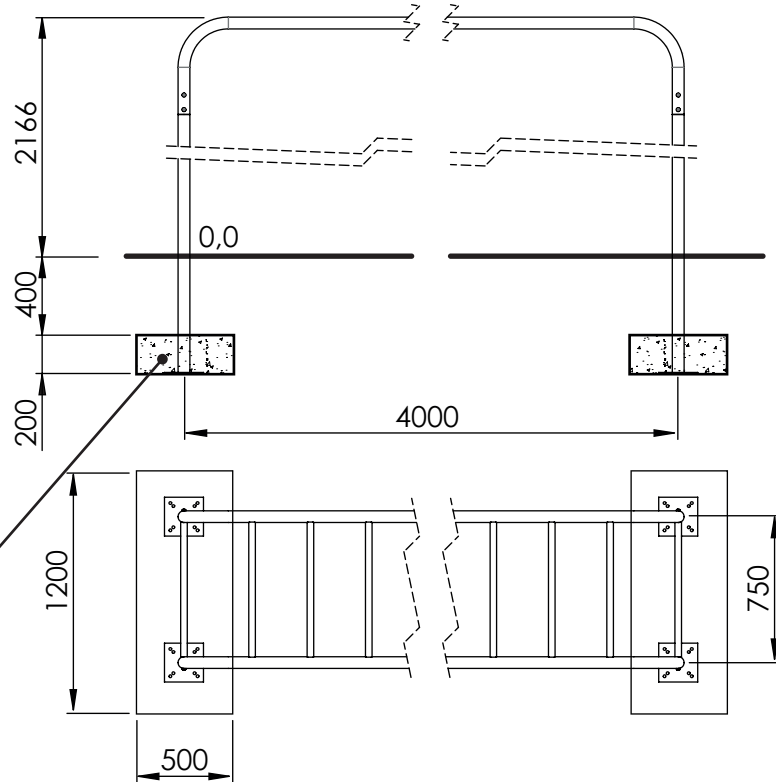

**34**



  
 S2 (50mm)  
 ≥C20-25

 7 x 24h

 **101**

Key	Art No	Description	Qty
1	GYM570	Horizontal Ladder Upright	4
2	GYM571	Horizontal Ladder Top Frame	1
3	10291000	M10 Washer	16
4	10121030	M10 x 30 Resistorx	16

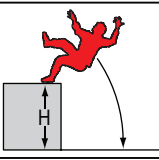
  
 EN 16630  
**1.15m**

# FS107 Parallel Bars

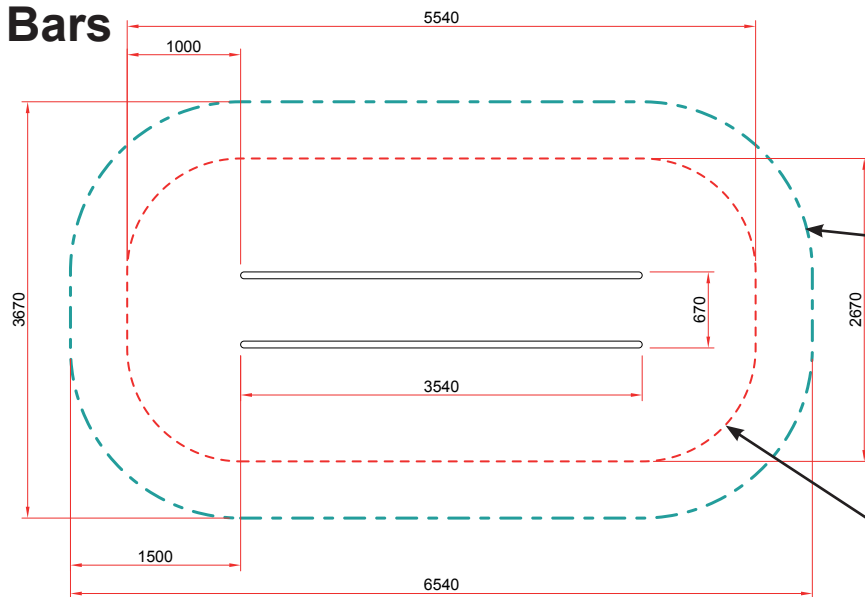

✓
← EN 16630
✗
← EN 16630

👁️ 📖 34



S2 (50mm) ≥C20-25
🕒 7 x 24h
👁️ 101

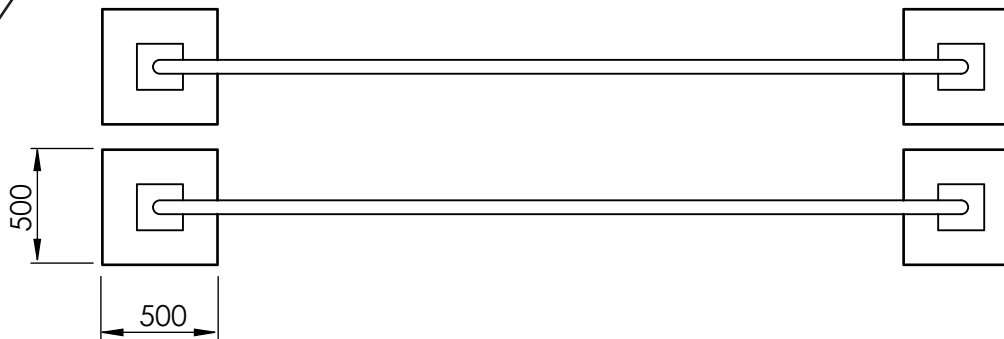

EN 16630
0.95m

# FS108 Chin Up

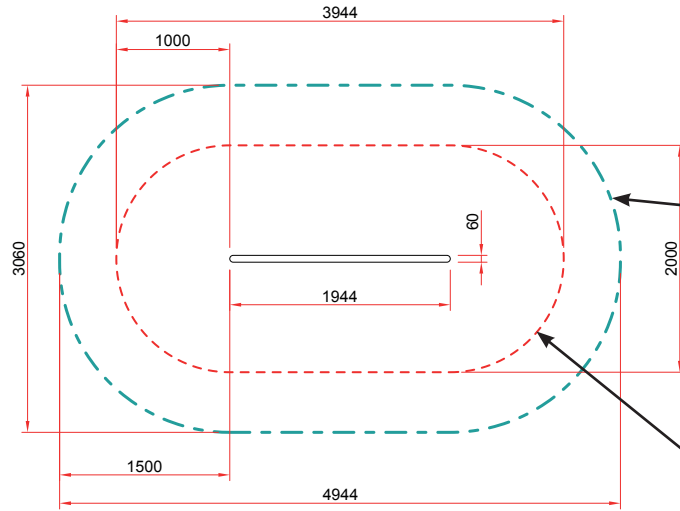

✓
← EN 16630
✗
← EN 16630

34

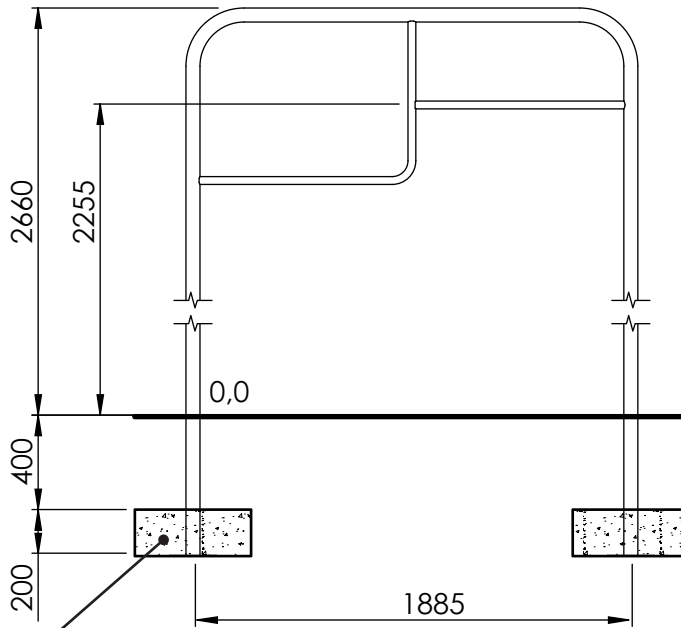

S2 (50mm) ≥C20-25
7 x 24h
101

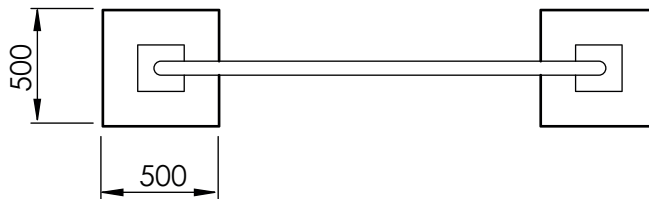

EN 16630
1.26m

# FS112 Step Up

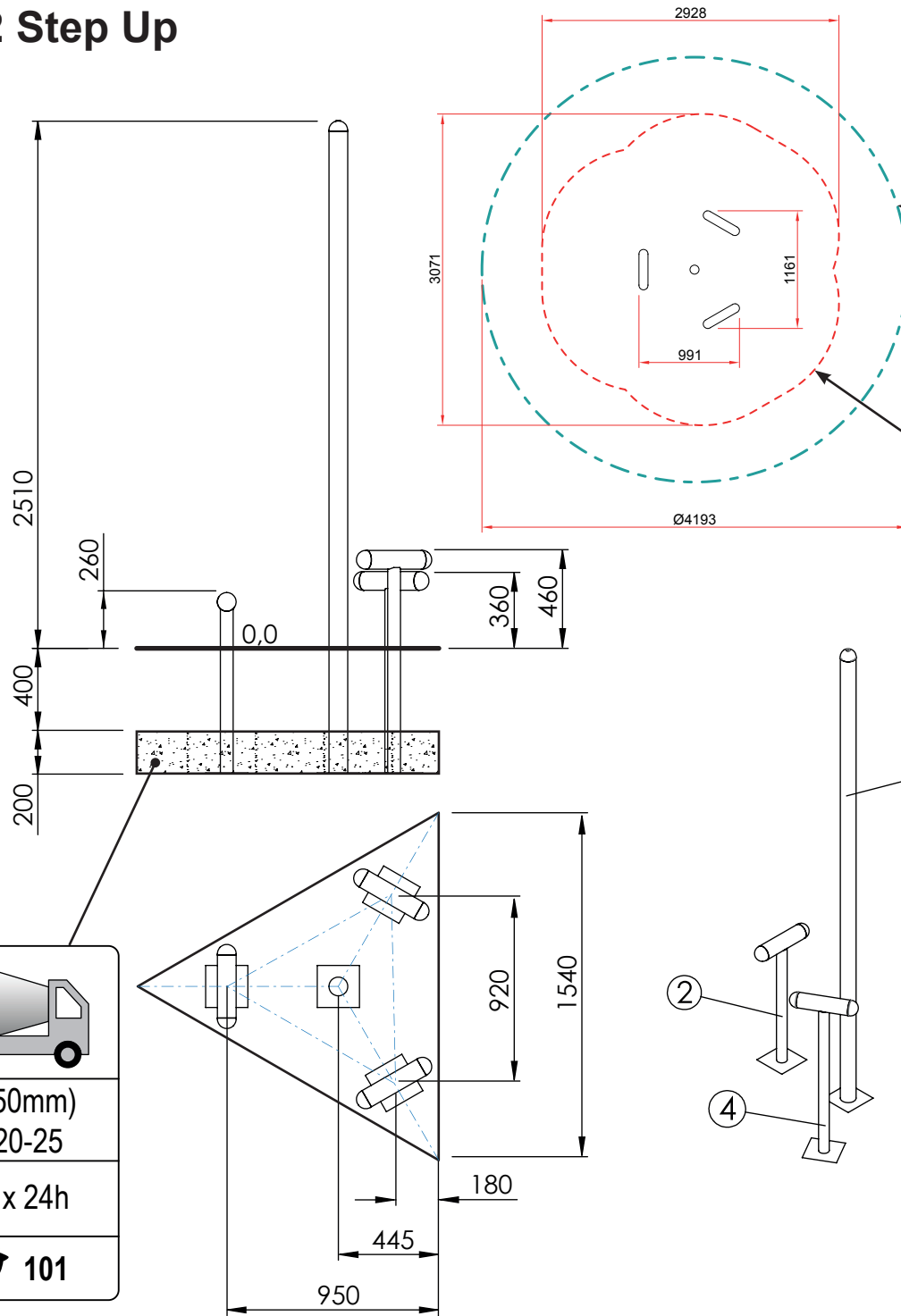

S2 (50mm)  
≥C20-25

7 x 24h

101

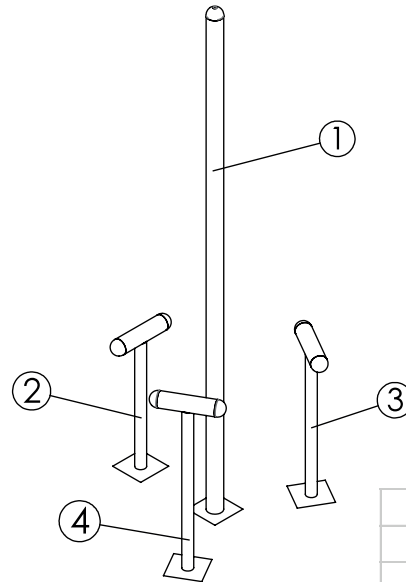

Key	Art No	Description	Qty
1	GYM512	Step Up Post	1
2	GYM556	860 Step Up	1
3	GYM557	960 Step Up	1
4	GYM558	1060 Step Up	1

EN 16630

EN 16630

34

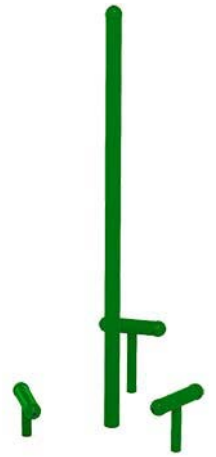





EN 16630

0.46m

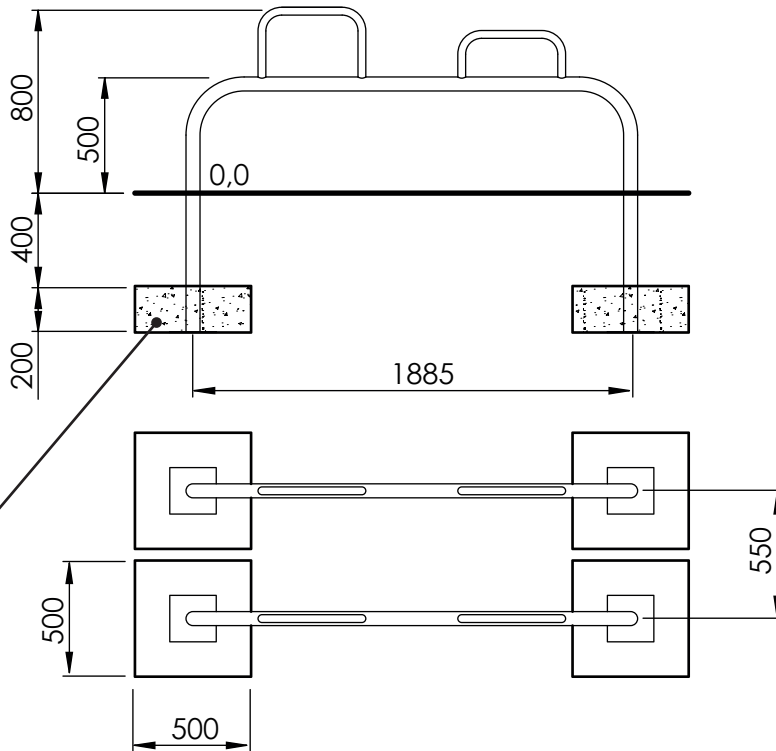
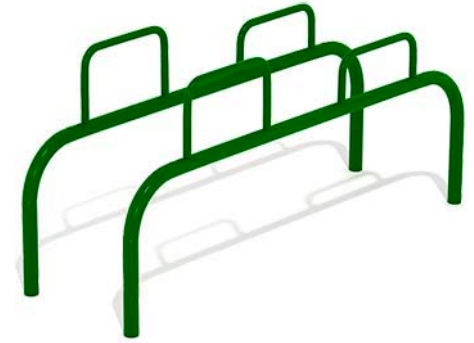
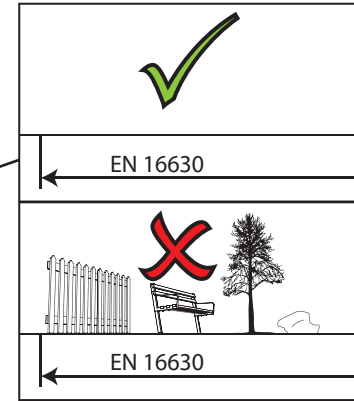
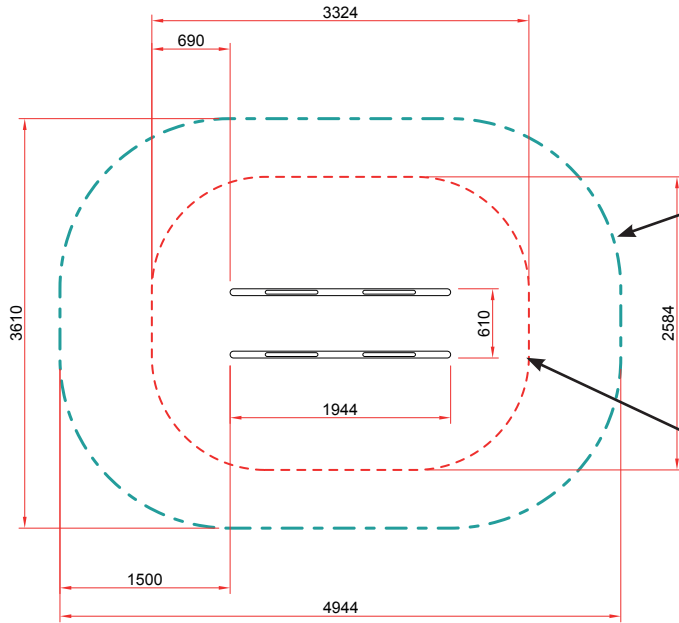

# FS113 Dip Station

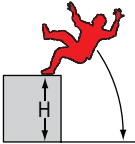

S2 (50mm) ≥C20-25
 7 x 24h
 101

EN 16630
0.8m

# Appendix A\_EN 16630 Zones

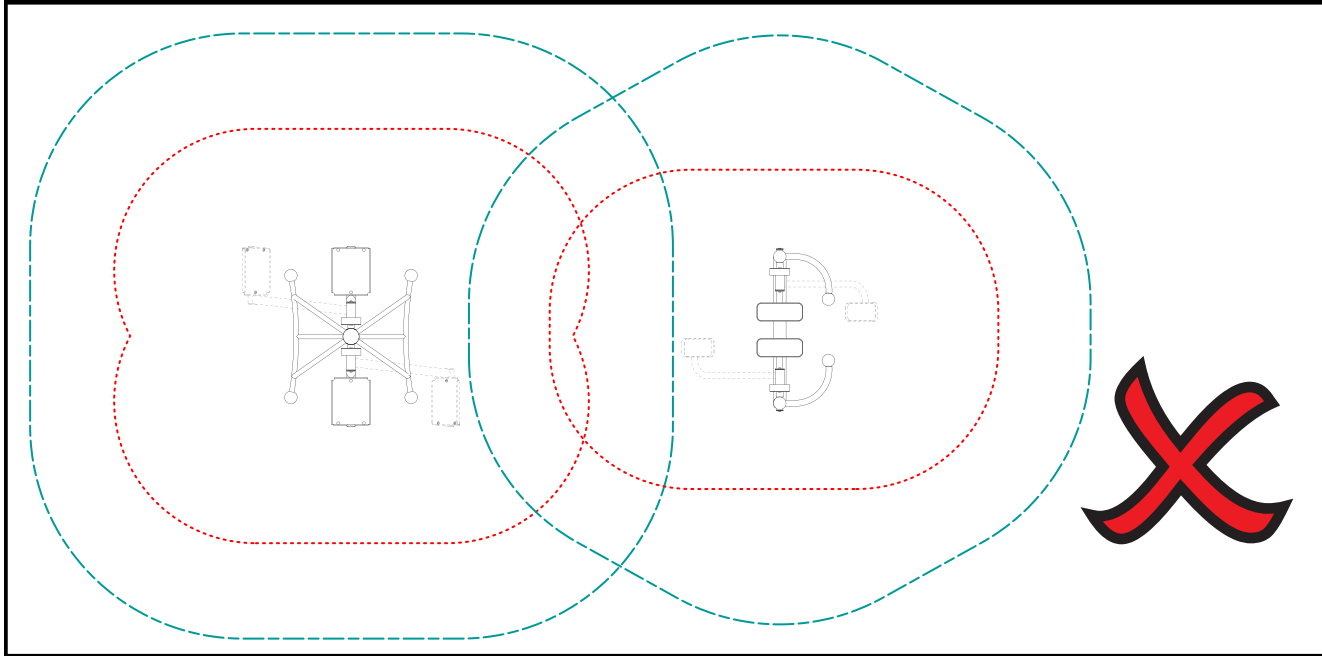
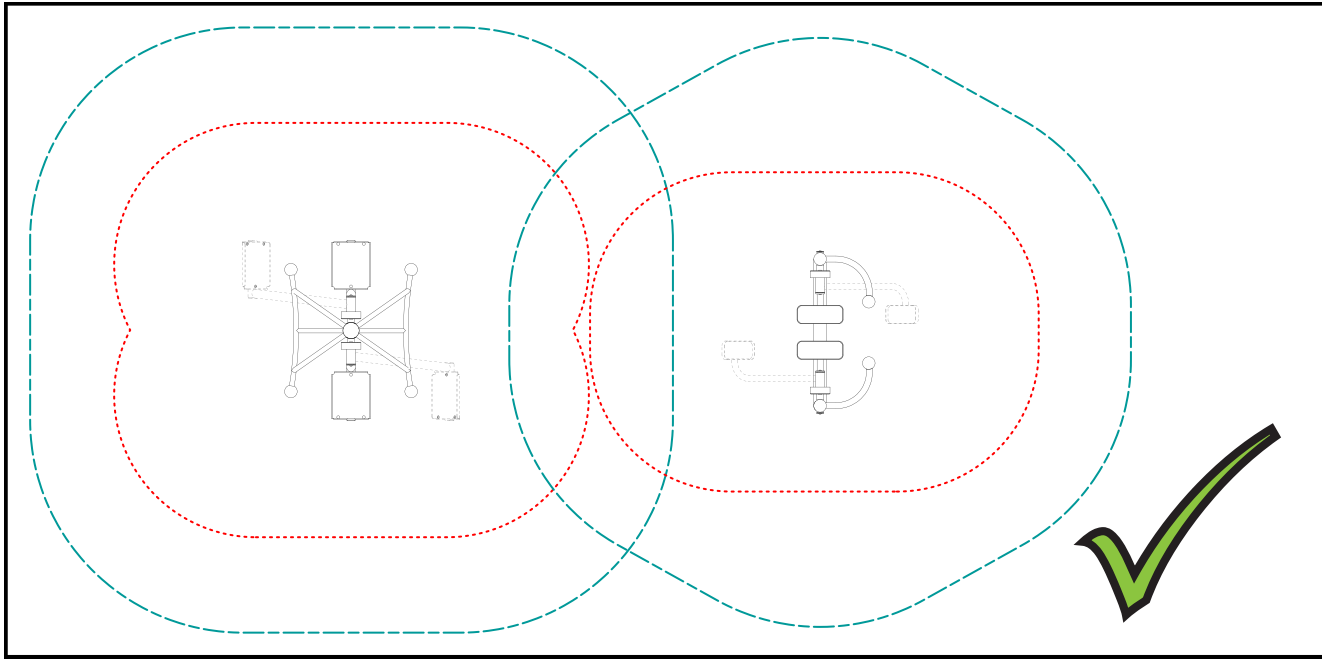

# Appendix B\_Rower-Position Check

